

SIMPLE MACHINES DELUXE™

WHEELS & AXLES
RUEDAS y EJES
ROUES et ESSIEUS

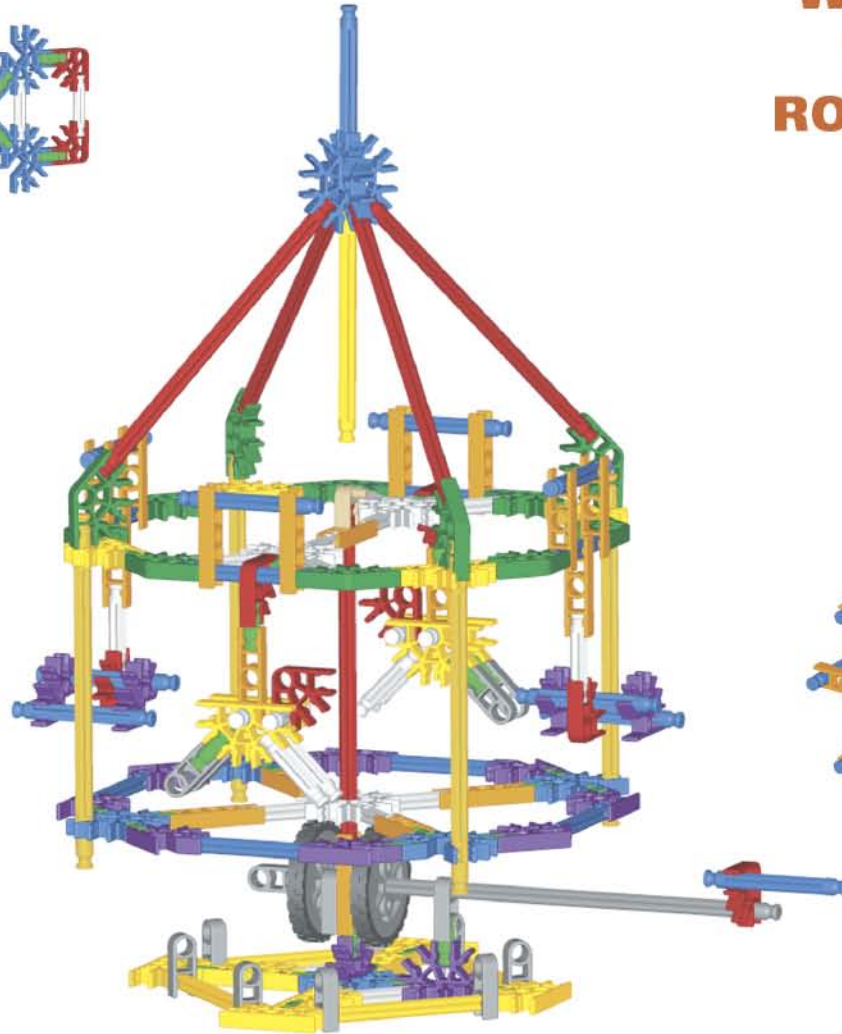

⚠ WARNING:

CHOKING HAZARD - Small parts.
Not for children under 3 years.

⚠ ADVERTENCIA:

PELIGRO DE ASFIXIA - Piezas pequeñas.
No es para niños menores de 3 años.

⚠ AVERTISSEMENT :

DANGER D'ÉTOUFFEMENT - Pièces de petite taille.
Ne convient pas aux enfants de moins de 3 ans.

GRADES
GRADOS
ANNÉES
3-9

8+

EN CONTENTS

Spinner 3
 Wishing Well 4
 Wheel and Axle Variations 5
 Wrench 7
 Screwdriver 8
 Ferris Wheel 9
 Water Wheel 10
 Paddlewheel Boat 11
 Windmill 12
 Measuring Wheel 15
 Wagon 16
 Carousel 17

ES CONTENIDOS

Hilandero 3
 Deseo pozo 4
 Variaciones de ejes y de ruedas 5
 Tirón 7
 Destronillador 8
 Rueda de ferris 9
 Rueda hidráulica 10
 Timón de bote a remo 11
 Molino de viento 12
 Rueda de medición 15
 Vagón 16
 Tiovivo 17

FR CONTENUS

Fileur 3
 Vœux puits 4
 Variations des roues et de l'essieu 5
 Clé 7
 Tournevis 8
 Roue de ferris 9
 Roues à aubes 10
 Bateau roues à aubes 11
 Moulin à vent 12
 Roue d'arpage 15
 Wagon 16
 Carrousel 17

⚠ WARNING: CHOKING HAZARD - Small parts. Not for children under 3 years.

CAUTION: Keep hair, clothing and fingers away from moving parts.

⚠ AVERTISSEMENT : DANGER D'ÉTOUFFEMENT - Petites pièces. Ne convient pas aux enfants de moins de 3 ans.

ATTENTION : Gardez les pièces mobiles à l'écart des doigts, des vêtements et des cheveux.

⚠ ADVERTENCIA: PELIGRO DE ASFIXIA - Piezas pequeñas. No es para niños menores de 3 años.

PRECAUCIÓN: Mantén el pelo, la ropa y los dedos alejados de las piezas móviles.

⚠ CAUTION: Rubber Bands can cause injury from snap-back, breaking, or loss of control. While assembling models shown in instructions, hold Rubber Band tightly, and do not overstretch. Use Rubber Bands only as shown in these instructions. **DO NOT USE FRAYED OR TORN RUBBER BANDS.** Caution: Keep Rubber Bands away from face and eyes.

⚠ PRECAUCIÓN: Las gomas pueden causar daños si se sueltan con fuerza, se rompen o se pierde su control. Al construir los modelos que se muestran en las instrucciones, sujetar bien la goma y no estirla demasiado. Las gomas deben usarse únicamente como se indica en las instrucciones. **NO USAR GOMAS QUE ESTÉN DESGASTADAS NI RASGADAS.** Precaución: Mantenga las gomas elásticas alejadas de la cara y los ojos.

⚠ ATTENTION : Les élastiques peuvent causer des blessures en claquant, en se cassant ou quand on les manipule imprudemment. Tenez fermement l'élastique lors de l'assemblage du modèle en veillant à ne pas trop le tendre. N'utilisez les élastiques que selon les instructions. **N'UTILISEZ PAS D'ÉLASTIQUES ÉRAILLÉS OU DÉCHIRÉS.** Attention : Tenez les élastiques en caoutchouc à l'écart du visage et des yeux.

Each K'NEX piece has its own color and shape; match it to pieces in the picture instructions. Put pieces together exactly as pictures show. Be sure to put rods in the correct slots of connectors, so you have proper angles in your finished model.

Assurez-vous de bien assembler les tiges dans les fentes des connecteurs afin d'obtenir des angles corrects une fois le modèle fini. Asegurarse de colocar las varillas en las ranuras correctas de los conectores, de modo que al terminar el modelo, los ángulos sean los adecuados.

Chaque pièce K'NEX a une couleur et une forme bien à elle. Faites correspondre et montez les pièces les unes sur les autres en suivant exactement les instructions illustrées. Assurez-vous de bien assembler les tiges dans les fentes des connecteurs afin d'obtenir des angles corrects une fois le modèle fini.

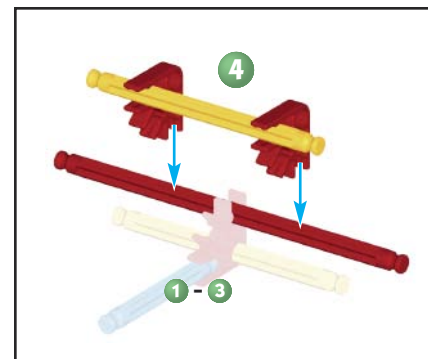
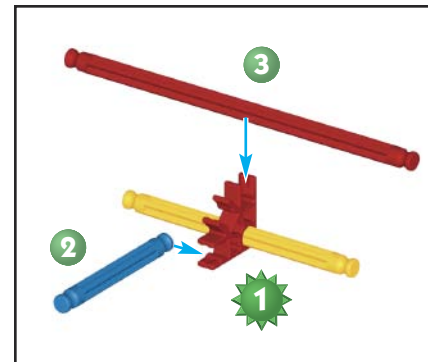

You can slide these special connectors together. Push tightly until you hear a "click". Pay close attention to the instructions and position them horizontally or vertically exactly as they are shown.

Se puede juntar estos conectores especiales deslizando los. Empujar ligeramente hasta oír un "clic". Hace falta prestar mucha atención a las instrucciones y posicionar los conectores horizontal o verticalmente exactamente tal como se muestran.

Les connecteurs bleus et gris ont une longue encoche spécialement conçue pour s'emboîter les unes dans les autres, tel qu'illustré. Bien les pousser ensemble jusqu'à ce qu'un dé clic se fasse entendre.

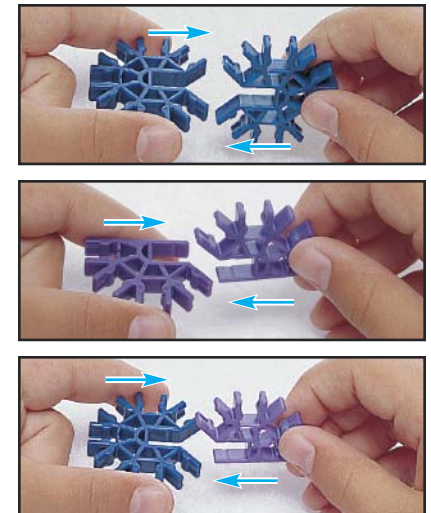

Faded colors indicate sections previously built; connecting points will be in full color.

Los colores apagados indican secciones que ya han sido montadas anteriormente. Los puntos de conexión se indican con colores vivos.

Les couleurs plus claires indiquent les sections déjà construites. Les points de jonction sont indiqués en couleurs vives.

Spinner Hiladero Fileur

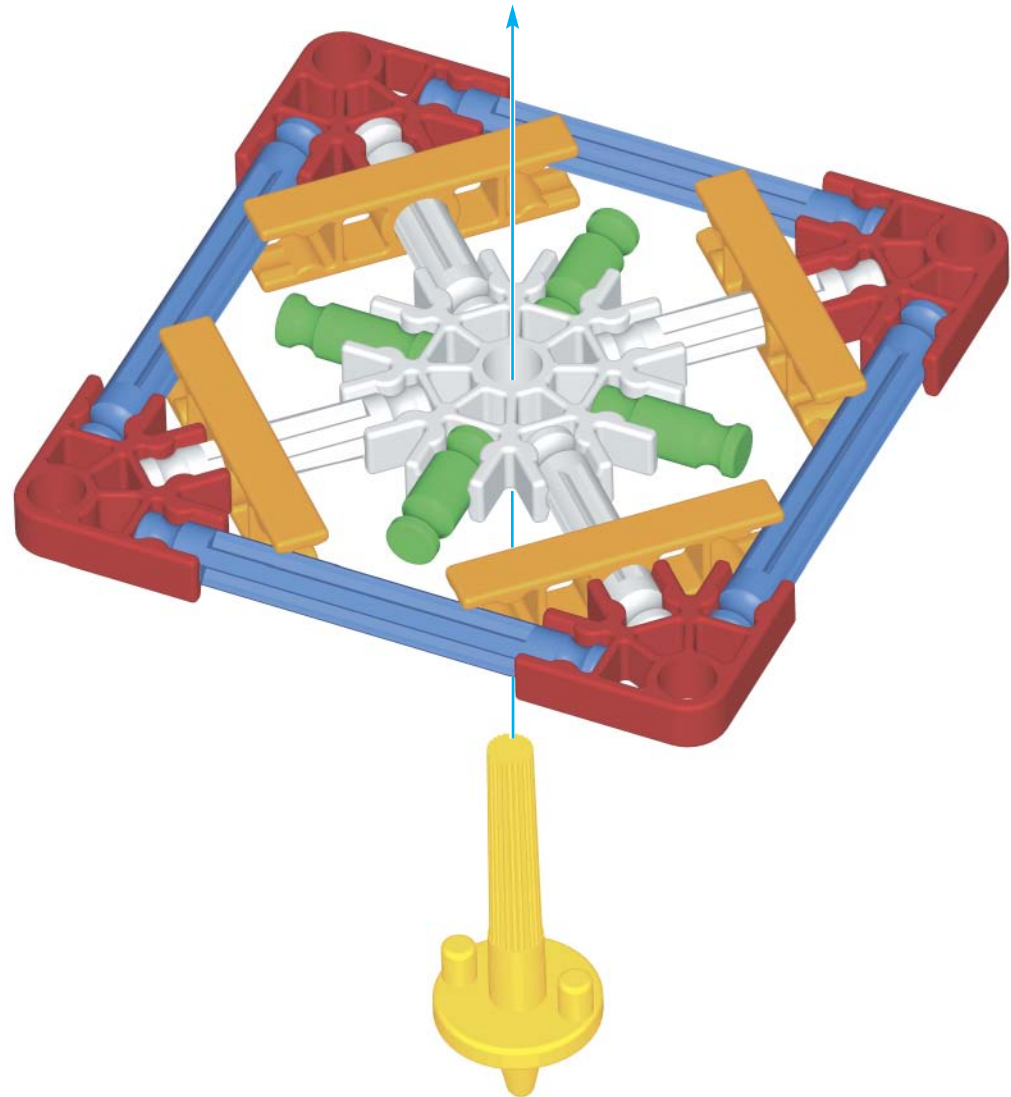
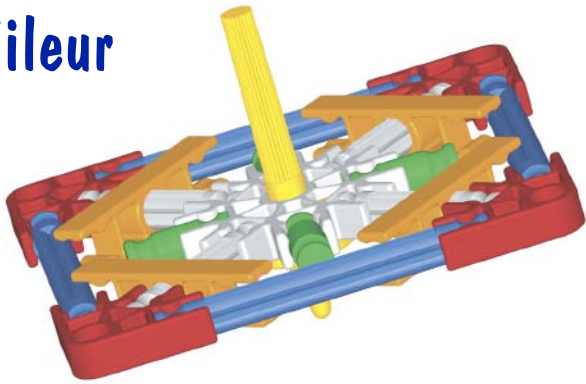

K'NEX Education

4		4		1	
4		4			
1		4			

Wishing Well

Deseo pozo

Vœux puits



K'NEX Education

2		47		1	
11		22		1	
26		26			
8		4			
18		9			
16		4			
8		1			
5		1			



Bucket

Cubo

Seau

2

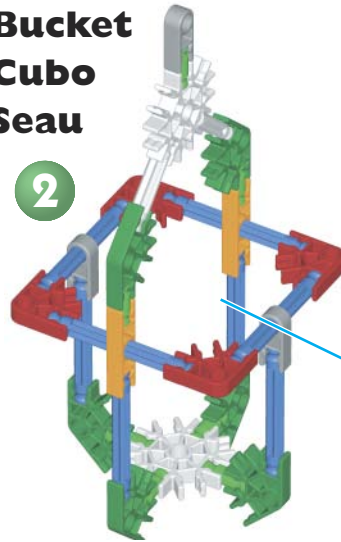

3

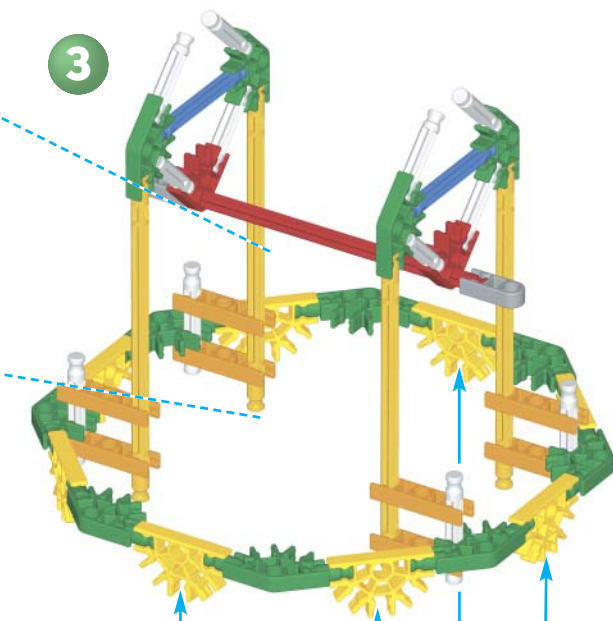
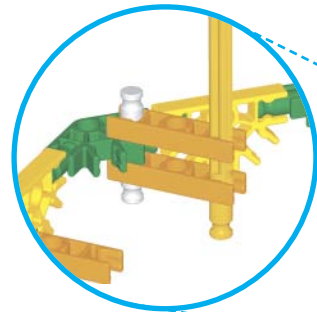

1

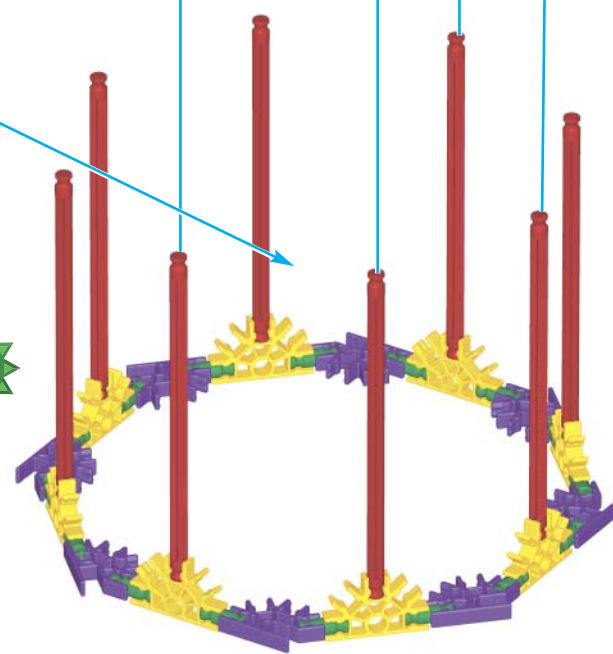

Place a cup of pennies in bucket for weight.

Coloque una taza de monedas de un centavo en el cubo para pesar.

Placer quelques sous dans le bac pour vérifier le poids.

Wheel & Axle Variations

Variaciones de ejes y de ruedas

Variations des roues et de l'essieu

Wheel & Axle 1
Rueda y ejes 1
Roues et essieux 1

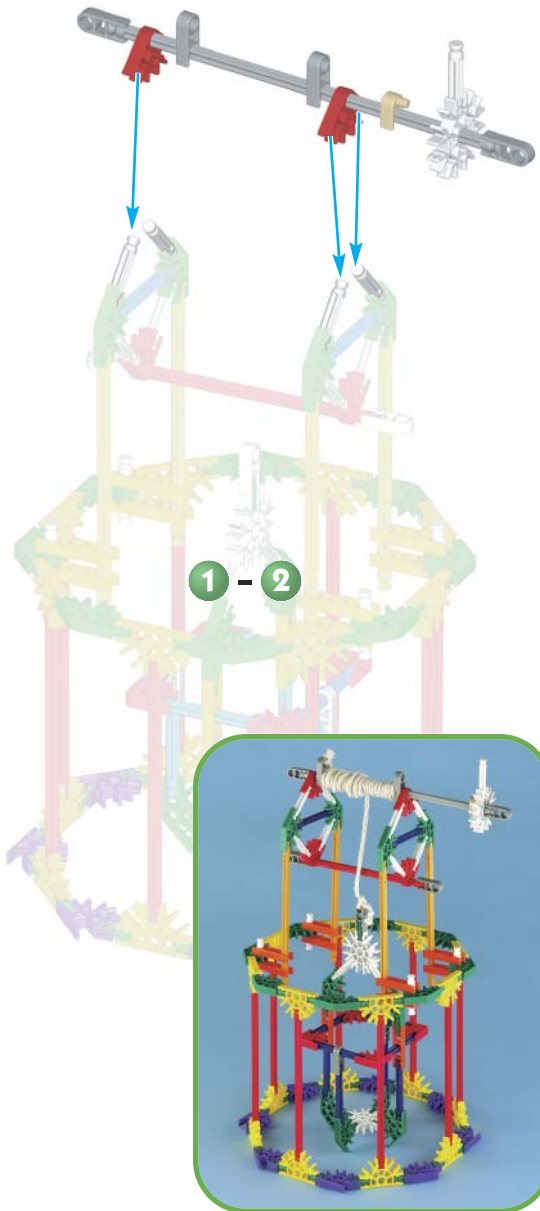

Wheel & Axle 2
Rueda y ejes 2
Roues et essieux 2

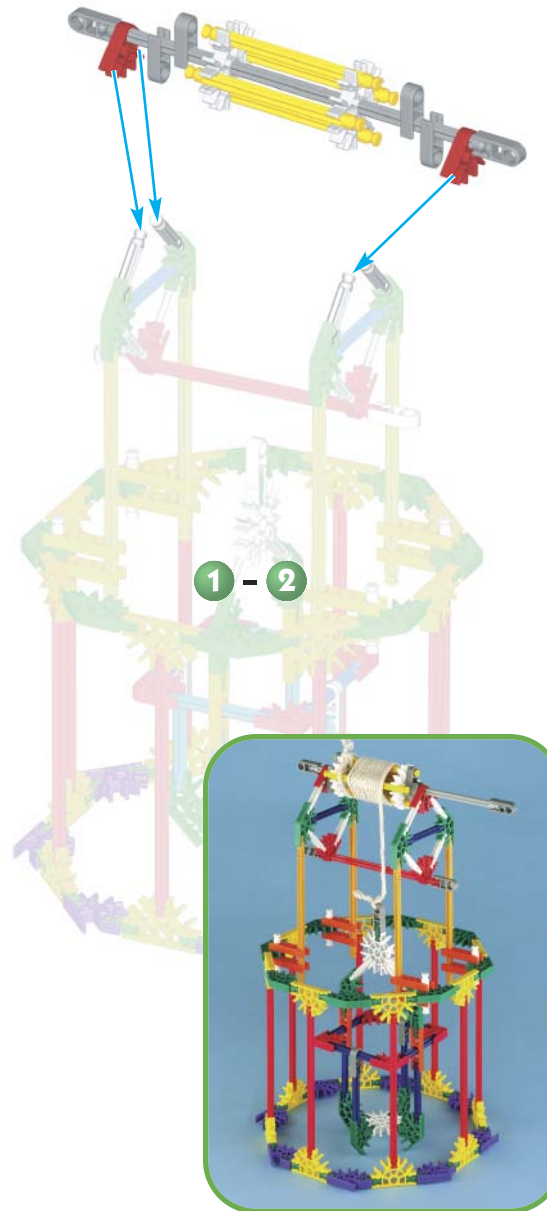

Wheel & Axle 3
Rueda y ejes 3
Roues et essieux 3

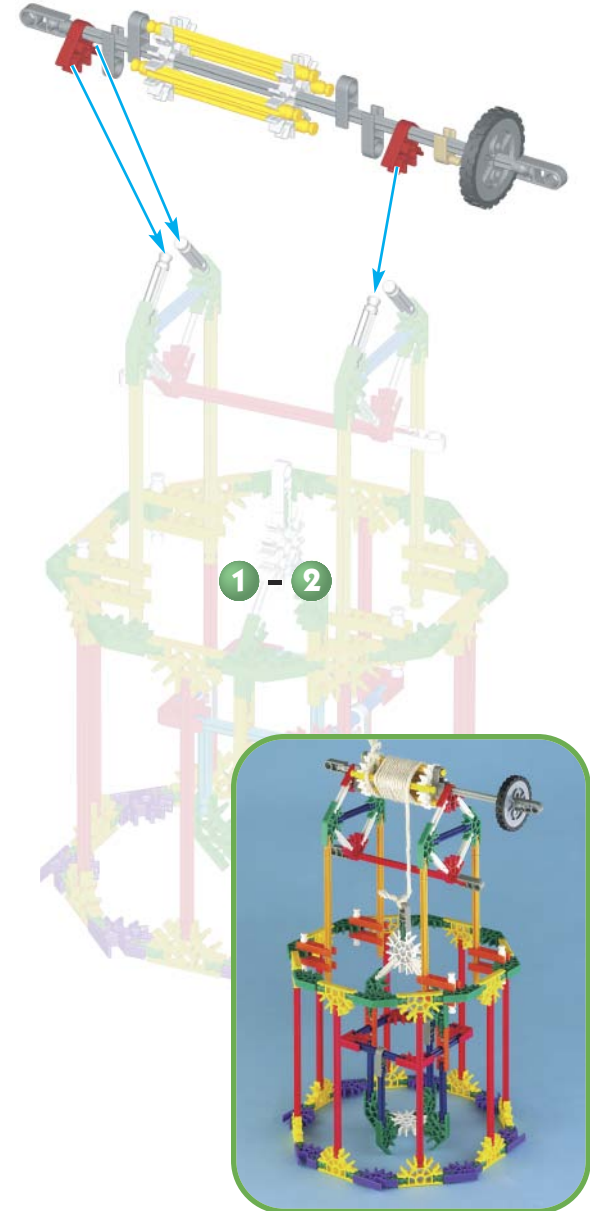

Wheel & Axle 4
Rueda y ejes 4
Roues et essieux 4

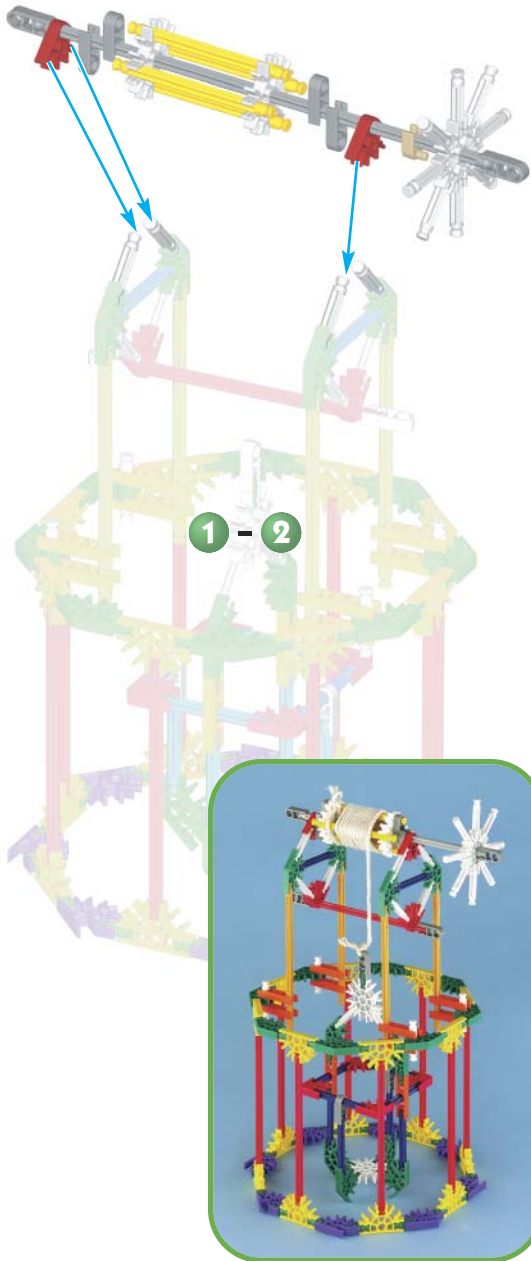

Wheel & Axle 5
Rueda y ejes 5
Roues et essieux 5

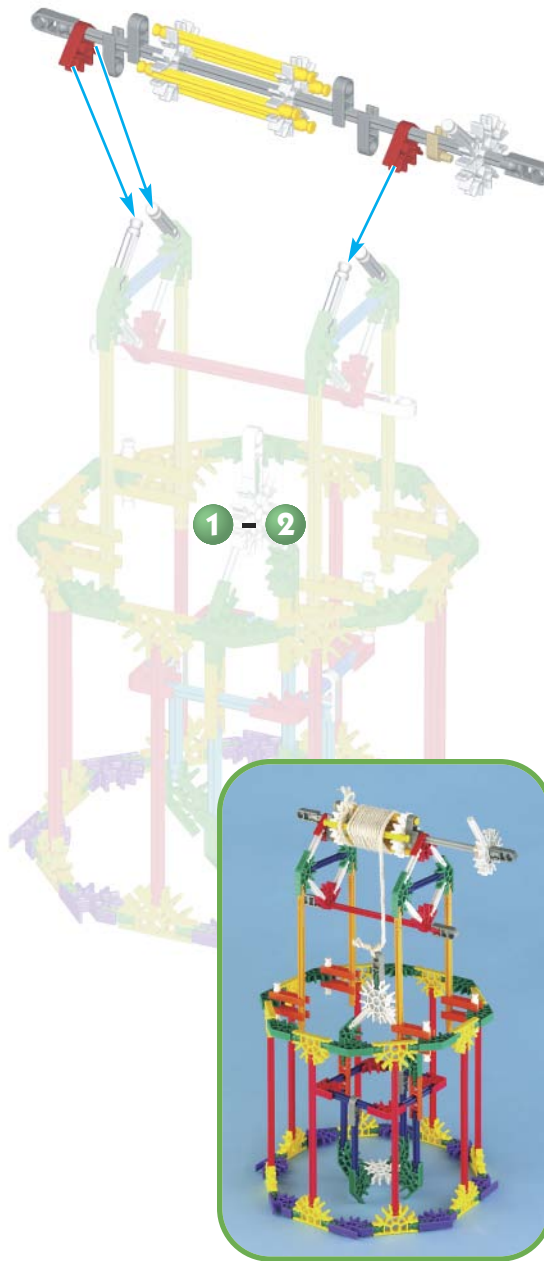

Wheel & Axle 6
Rueda y ejes 6
Roues et essieux 6

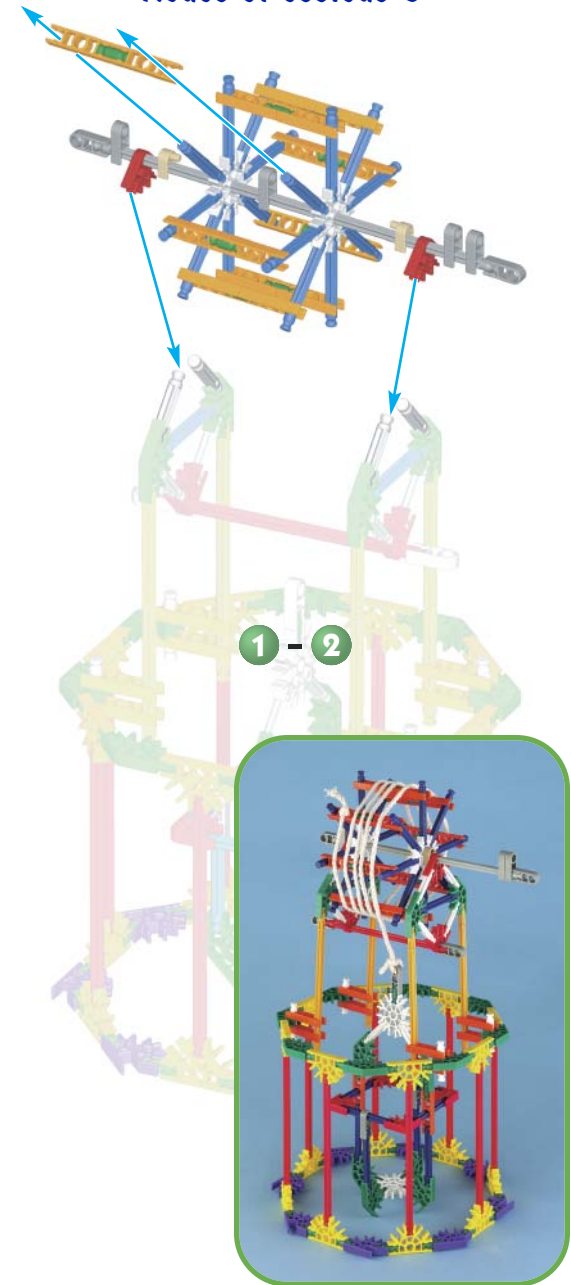

Wrench

Tirón
Clé



1

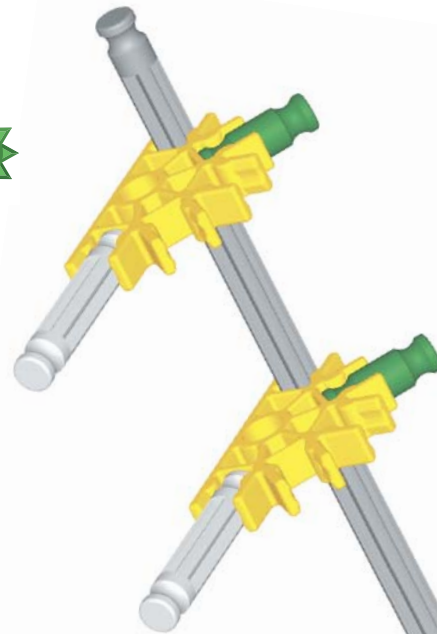

2

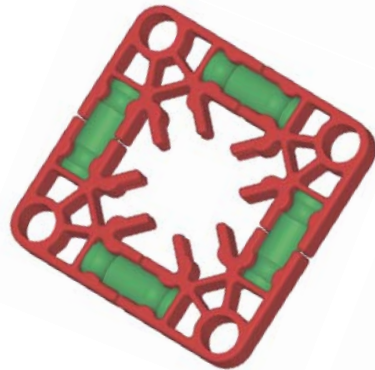

A = A

K'NEX Education

1		6	
4		2	
2		1	

Screwdriver Destornillador Tournevis

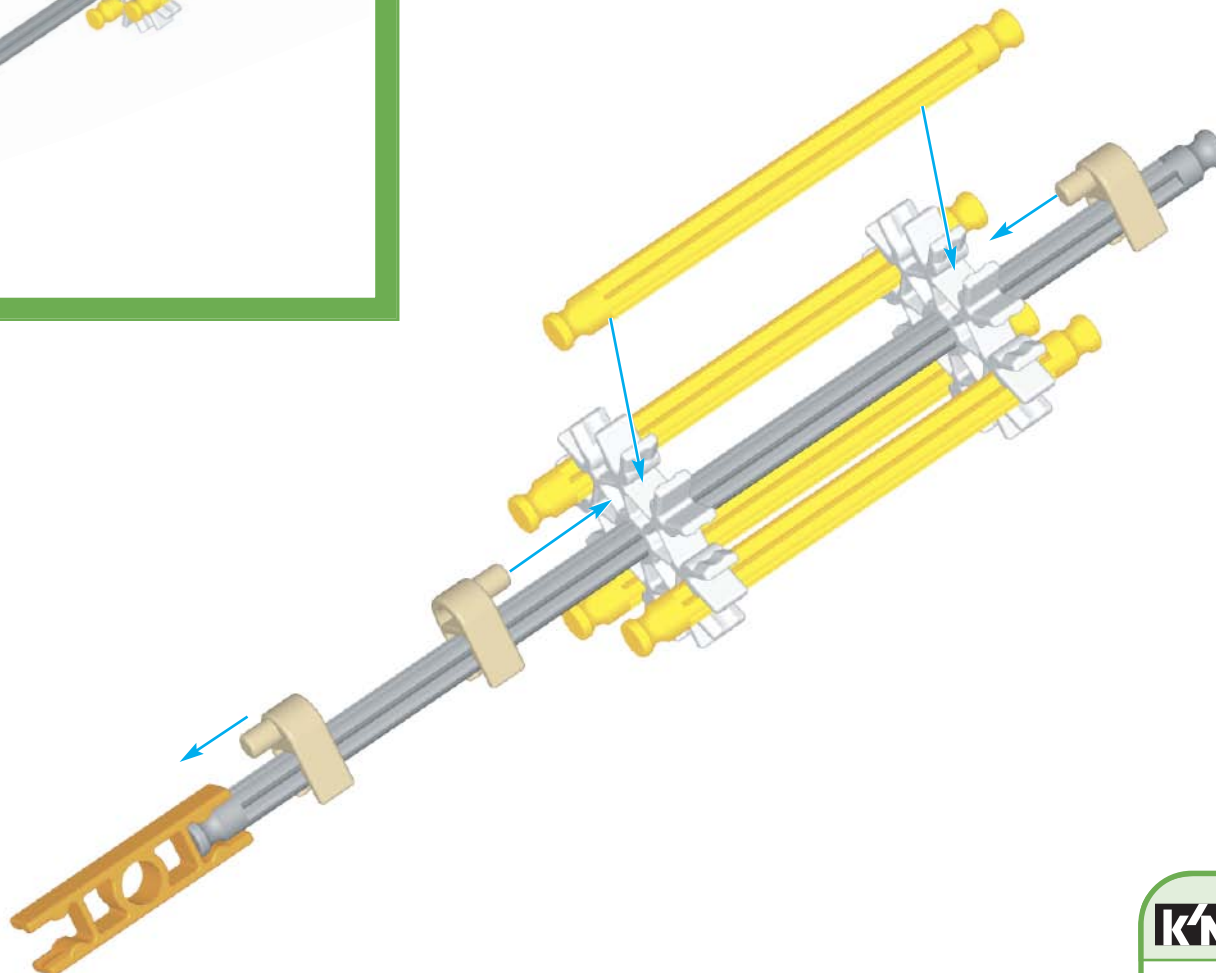
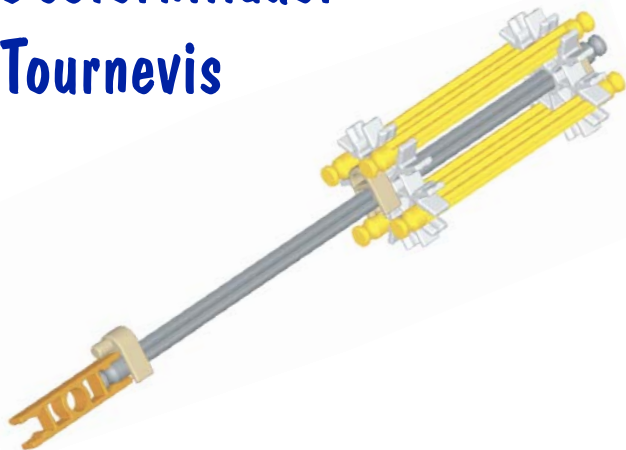

K'NEX Education

- | | | | |
|---|--|---|--|
| 3 | | 4 | |
| 1 | | 1 | |
| 2 | | | |

Ferris Wheel

Rueda de Ferris

Roue de Ferris

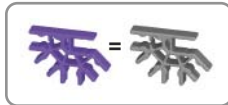
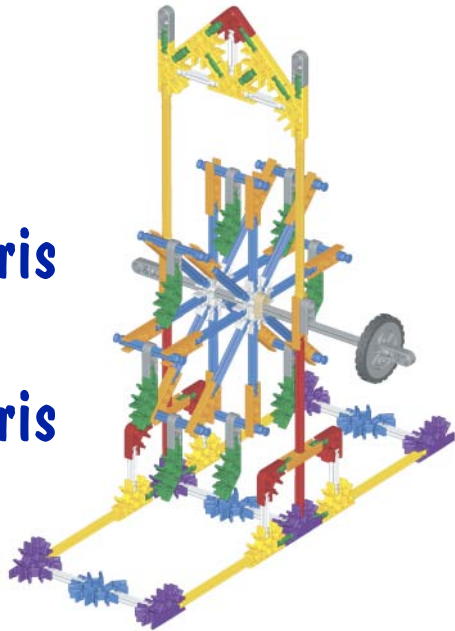

K'NEX Education

3		24	
13		13	
20		24	
5		4	
8		2	
9		1	
12		2	
3		1	
2		1	

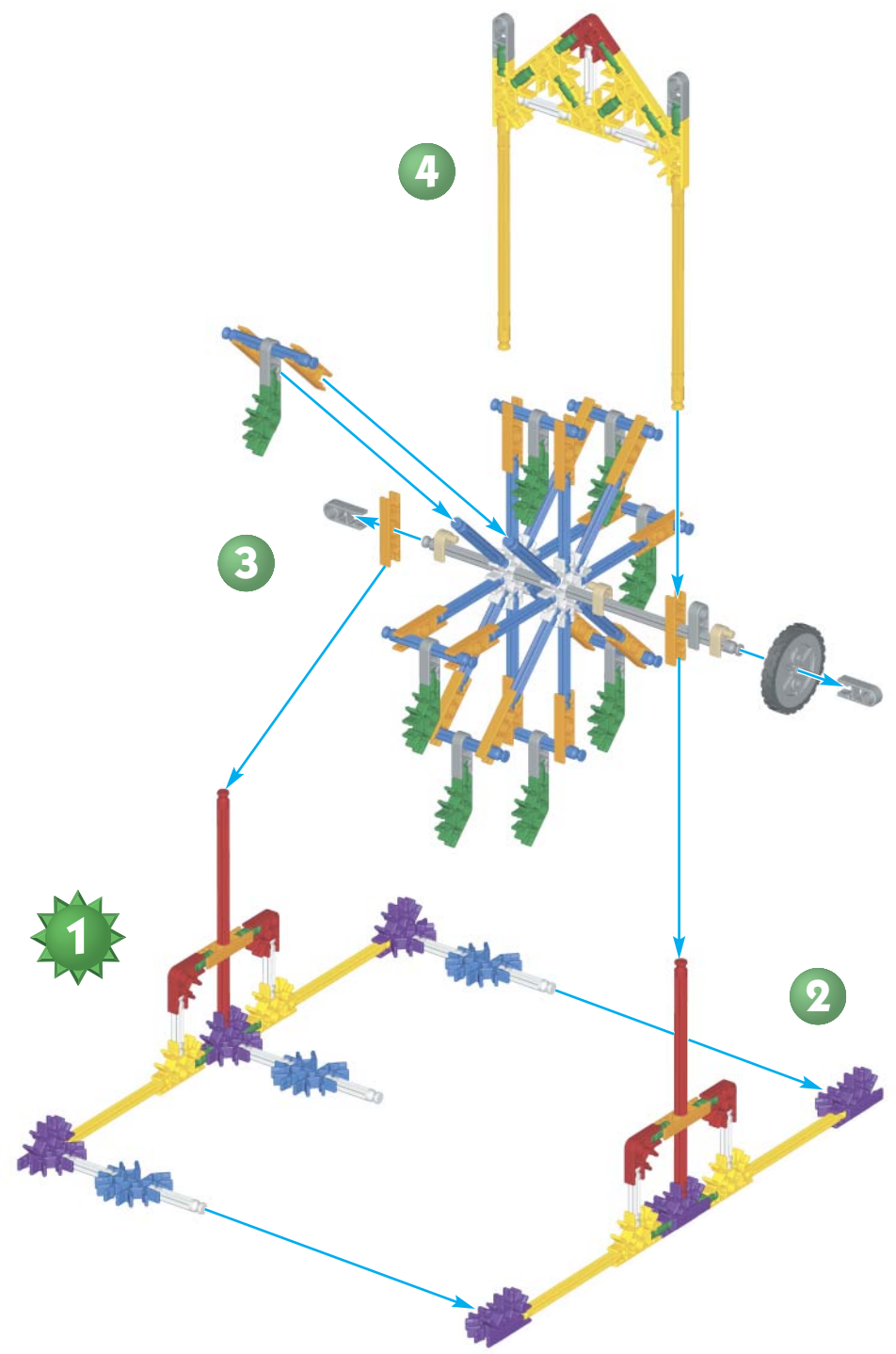

Water Wheel

Rueda
hidráulica

Roues à
aubes

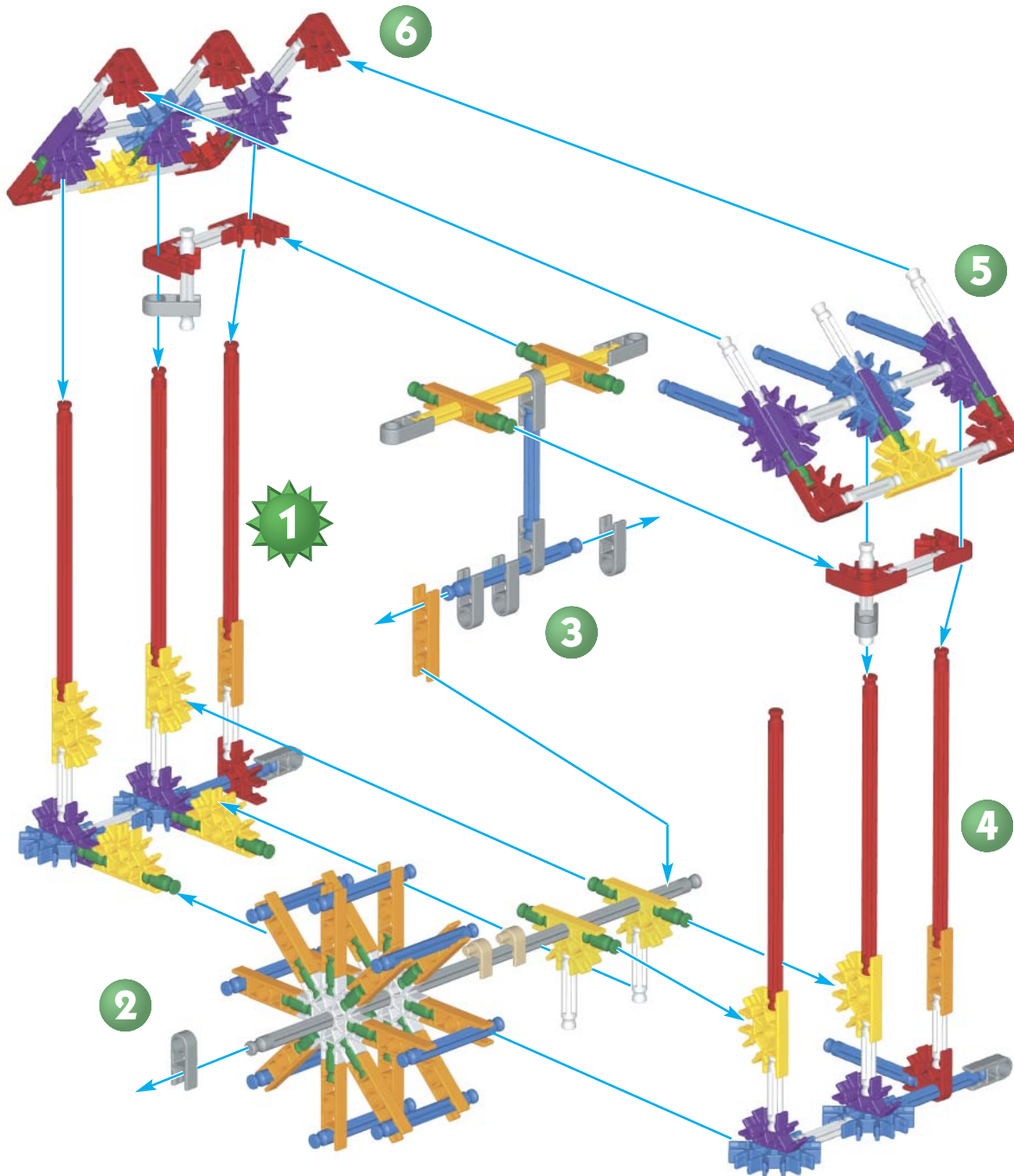

K'NEX Education

2		34	
12		28	
21		16	
13		1	
10		6	
14		1	
6			
2			

Paddlewheel Boat

Timón de bote a remo

Bateau
roues à
aubes



K'NEX Education

4		18	
2		32	
18		18	
4		4	
4		1	
8		1	
17			
1			
4			

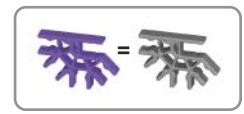

2

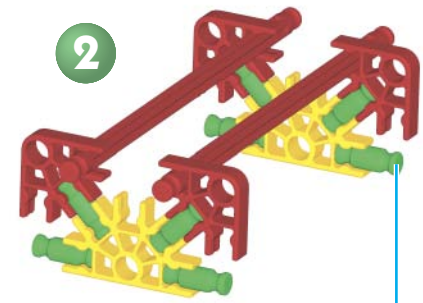

3

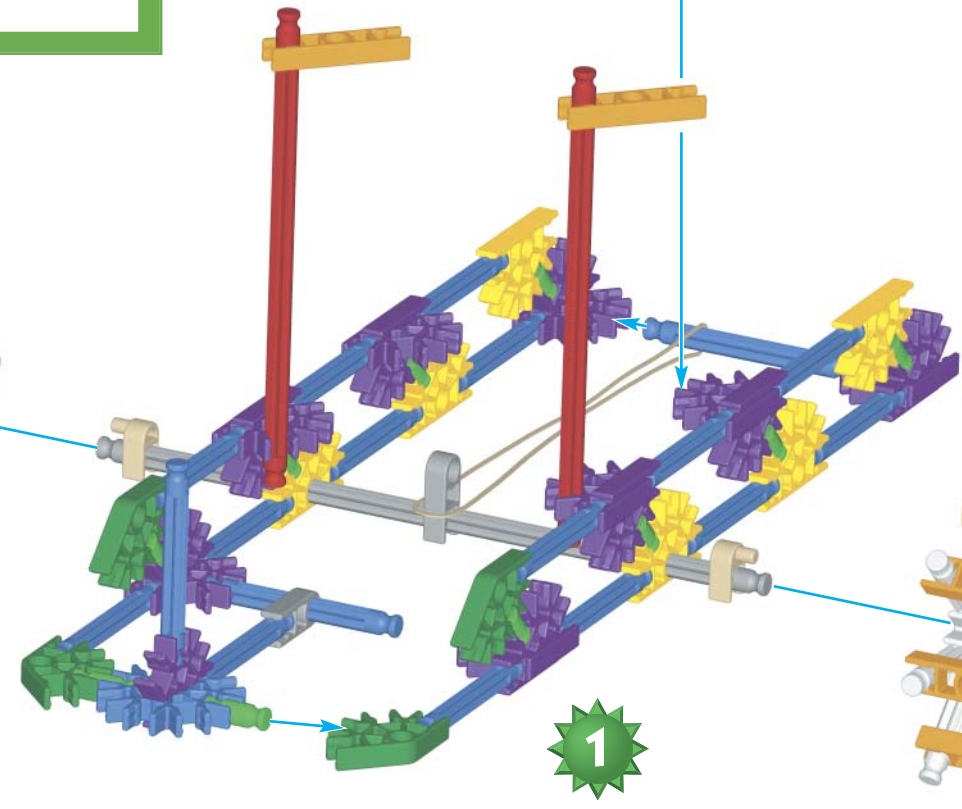
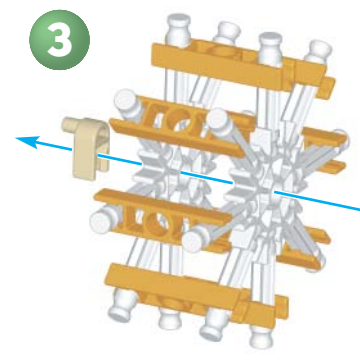

1

4

Windmill

Molino de viento

Moulin à vent



K'NEX Education

5		30	
13		18	
9		19	
10		4	
16		4	
16		1	
5			
3			

1

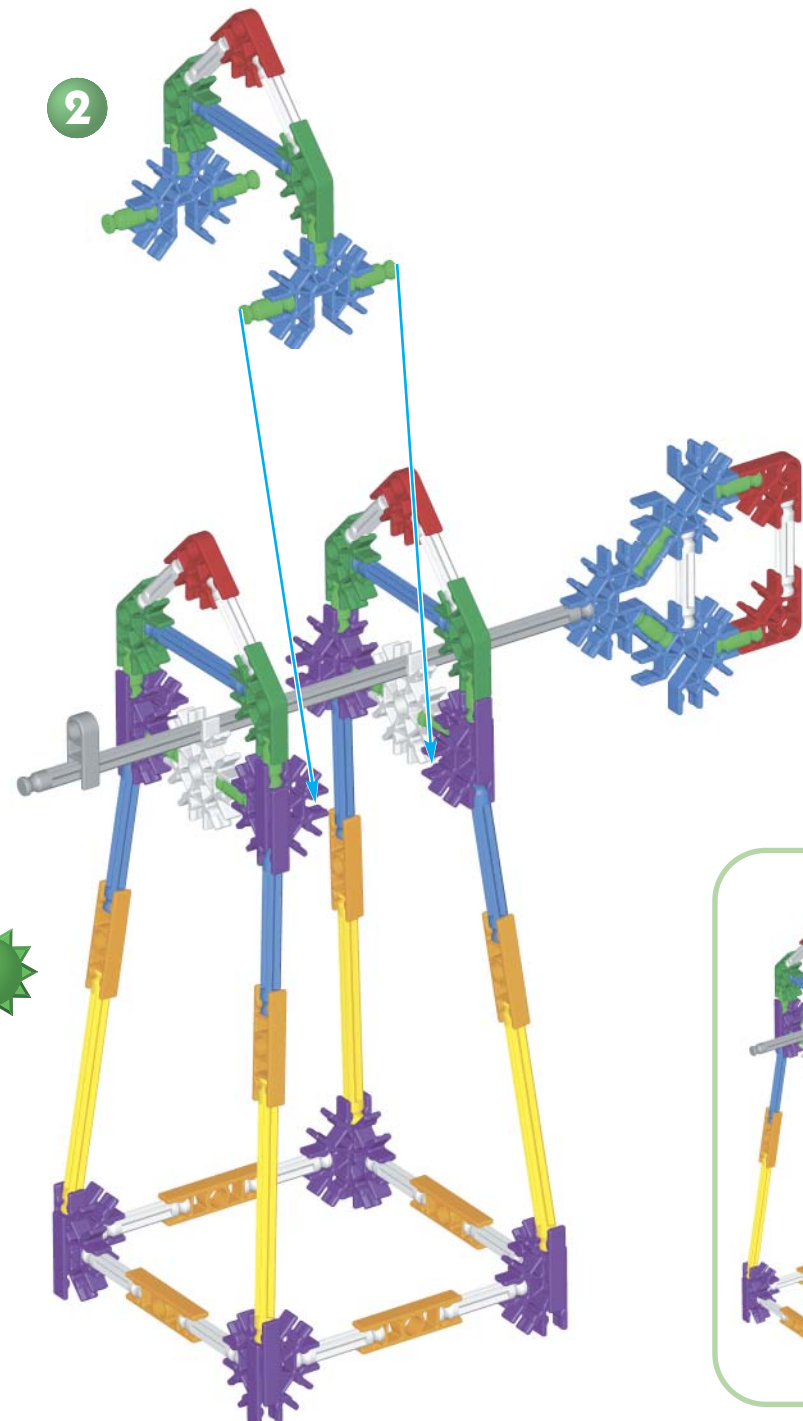

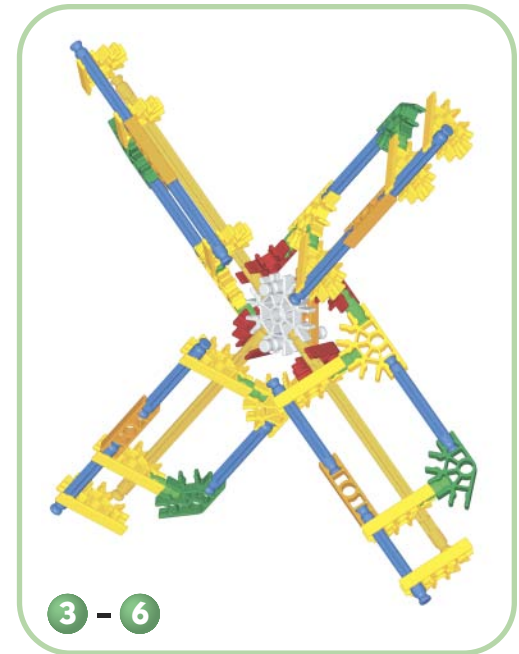
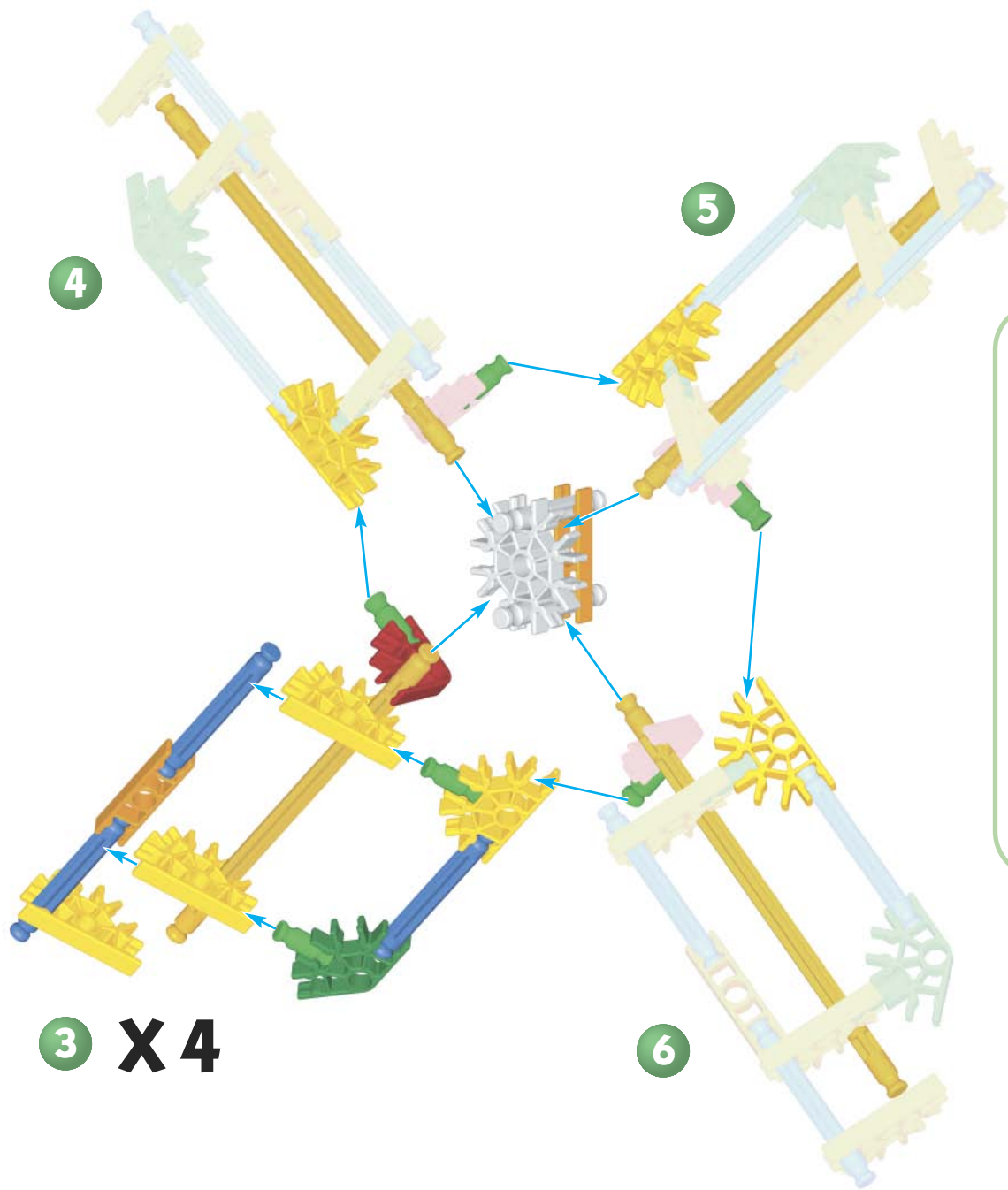

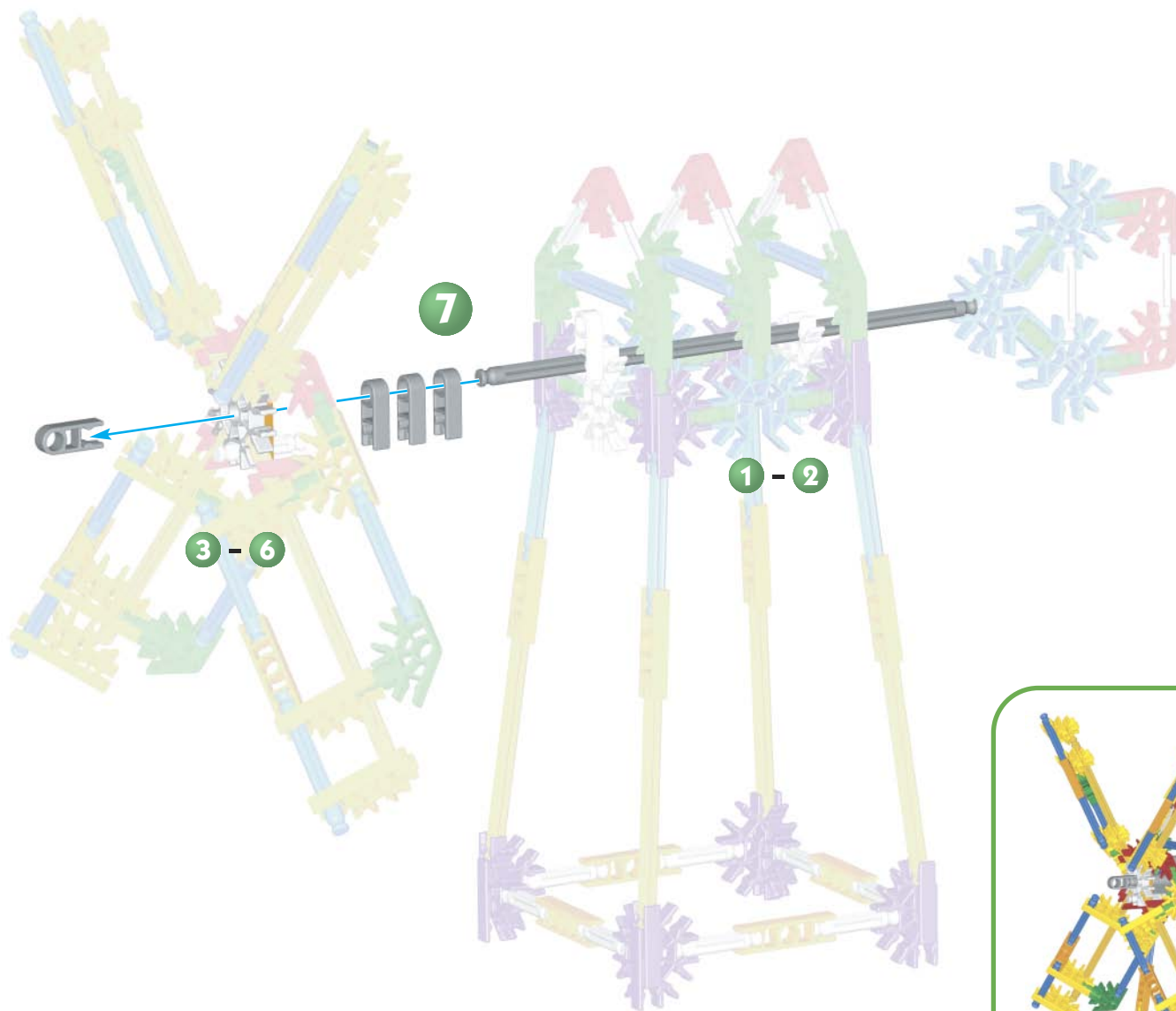



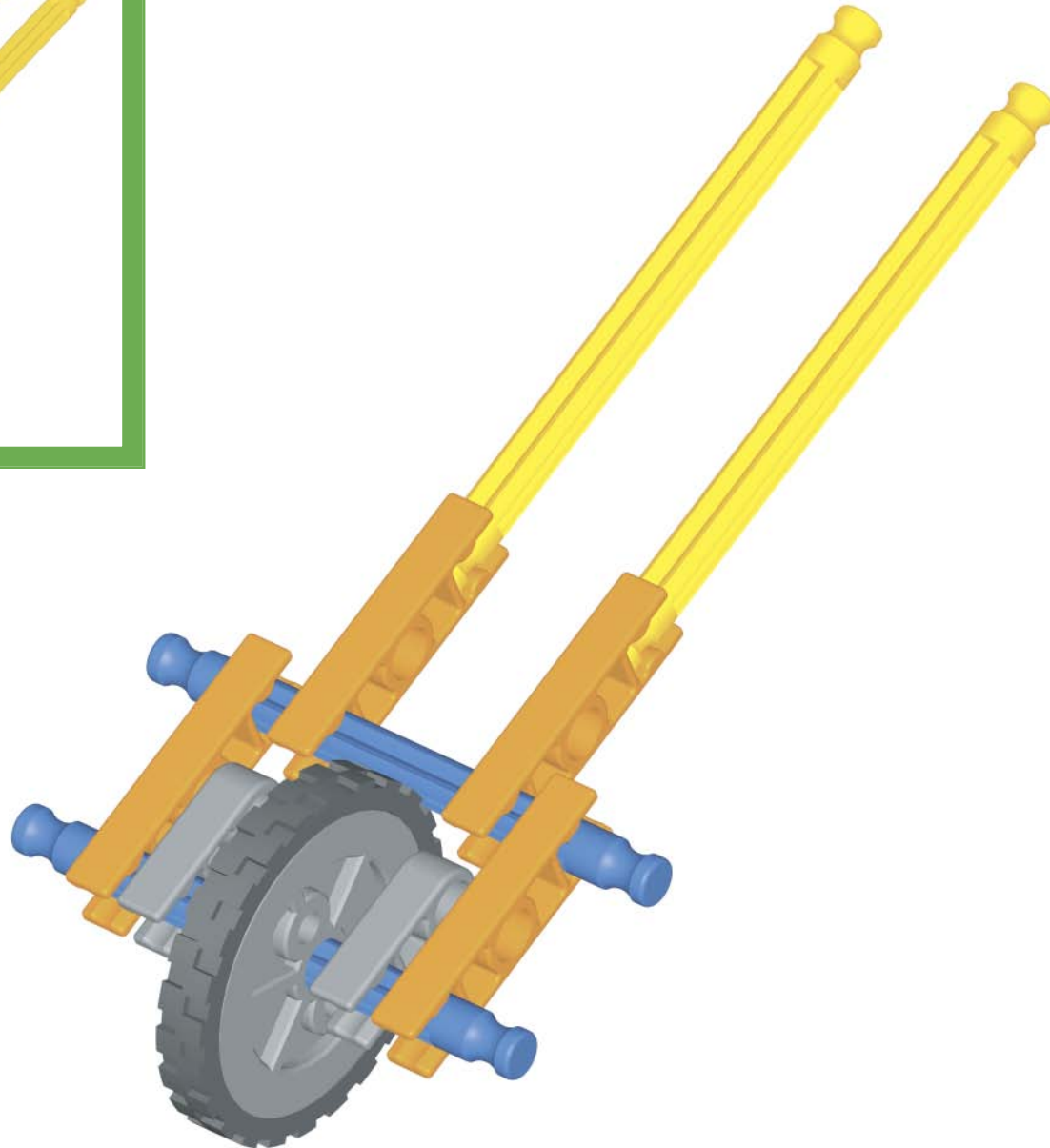



Measuring Wheel
 Rueda de medición
 Roue
 d'arpentage



K'NEX Education

2		2		1	
4		2		1	

Wagon Vagón Wagon

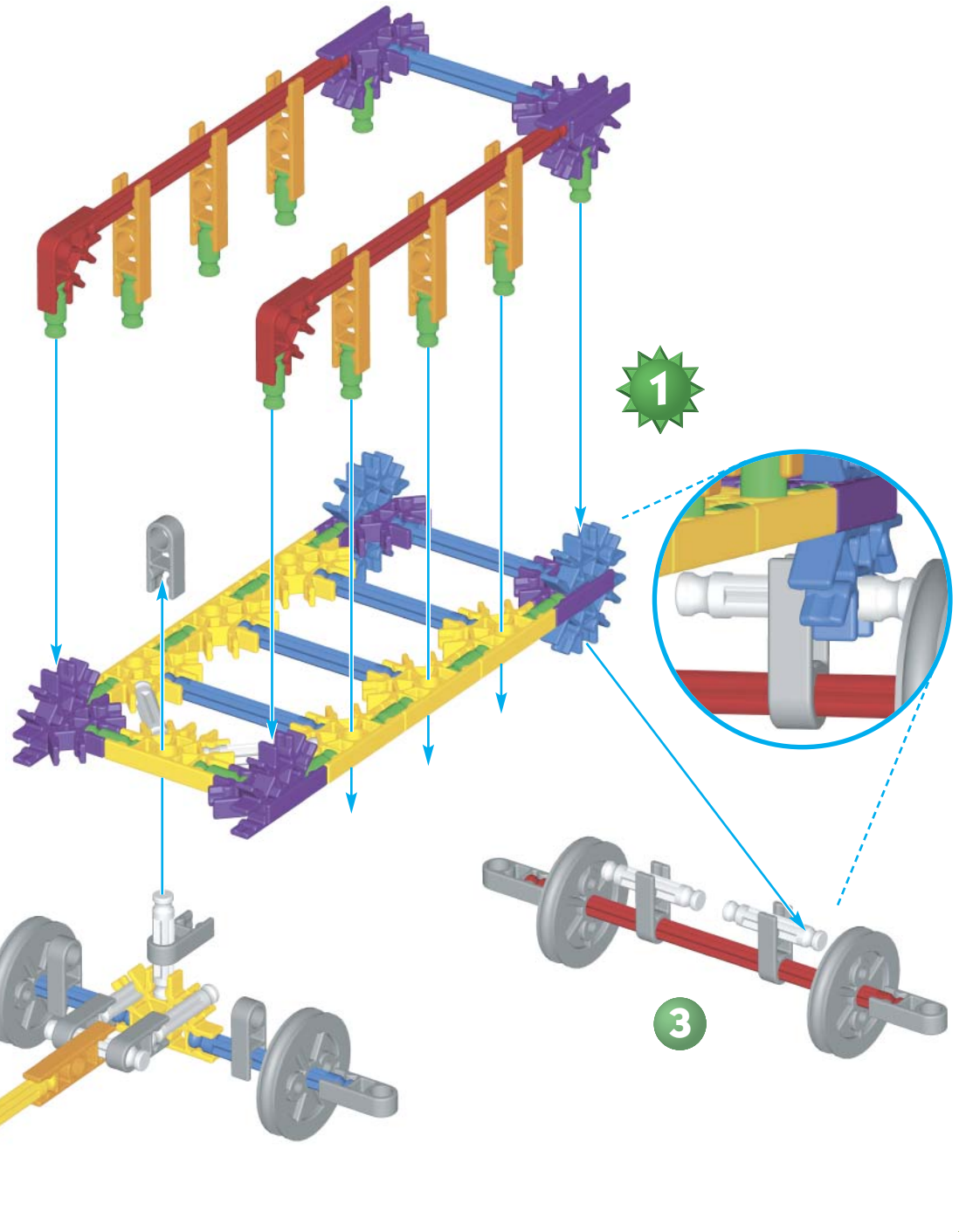
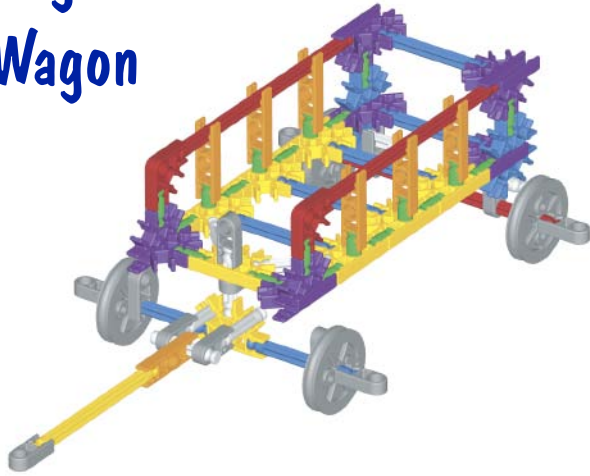

K'NEX Education

- | | | | | | |
|----|--|----|--|---|--|
| 13 | | 20 | | 4 | |
| 7 | | 8 | | | |
| 2 | | 7 | | | |
| 8 | | 1 | | | |
| 10 | | 3 | | | |
| 2 | | | | | |

Carousel Tiovivo Carrousel

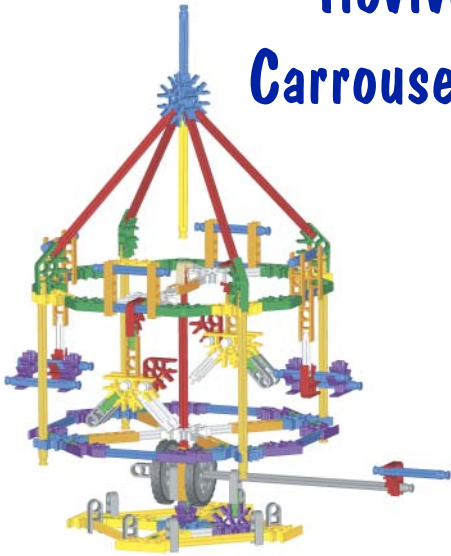

K'NEX Education

2		38		2	
15		22		2	
18		18			
7		5			
12		5			
15		4			
15		1			
7					
3					

2

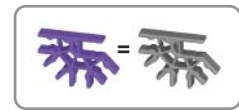
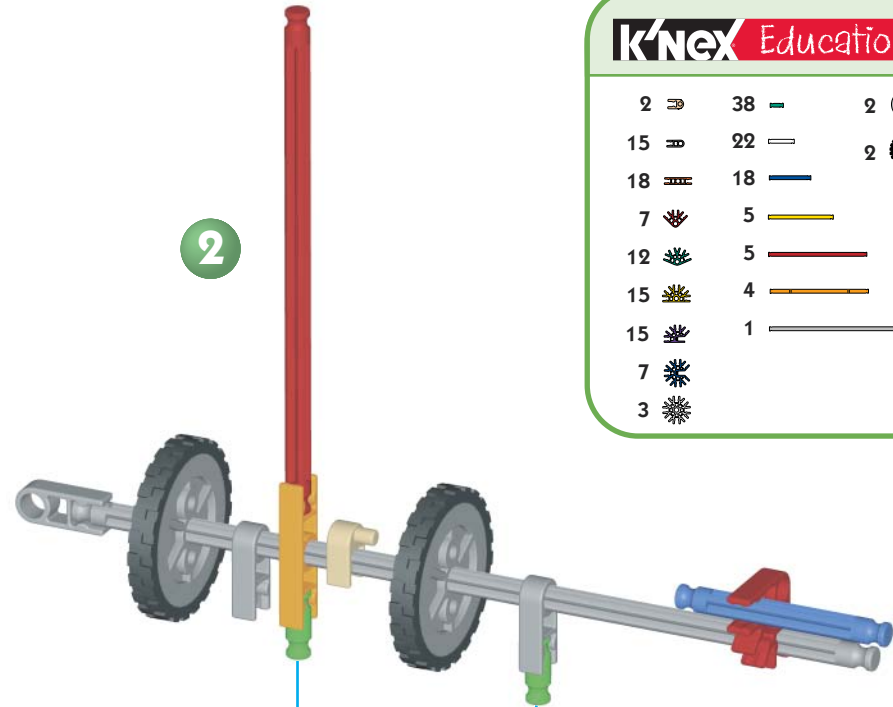

1

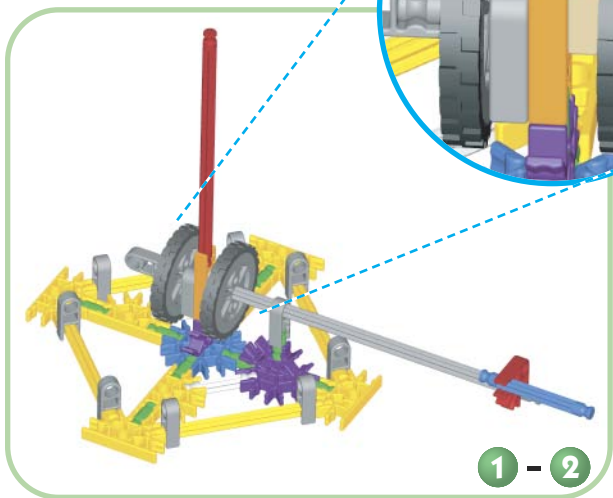
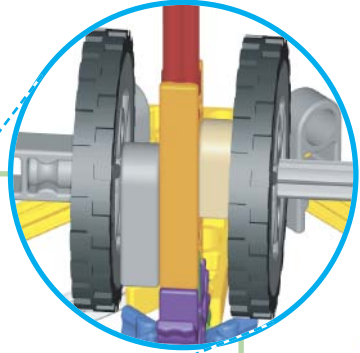
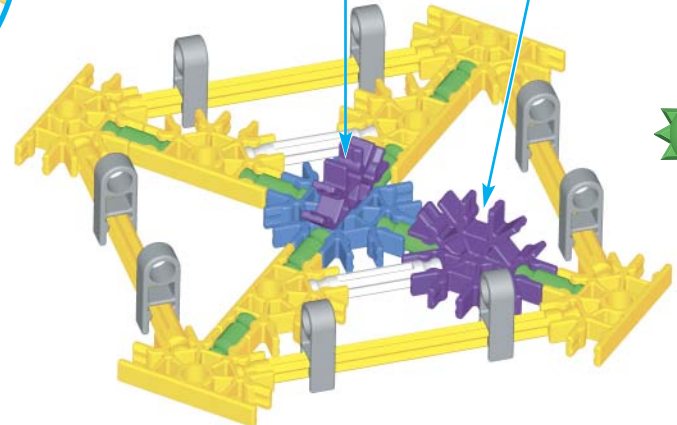

1 - 2

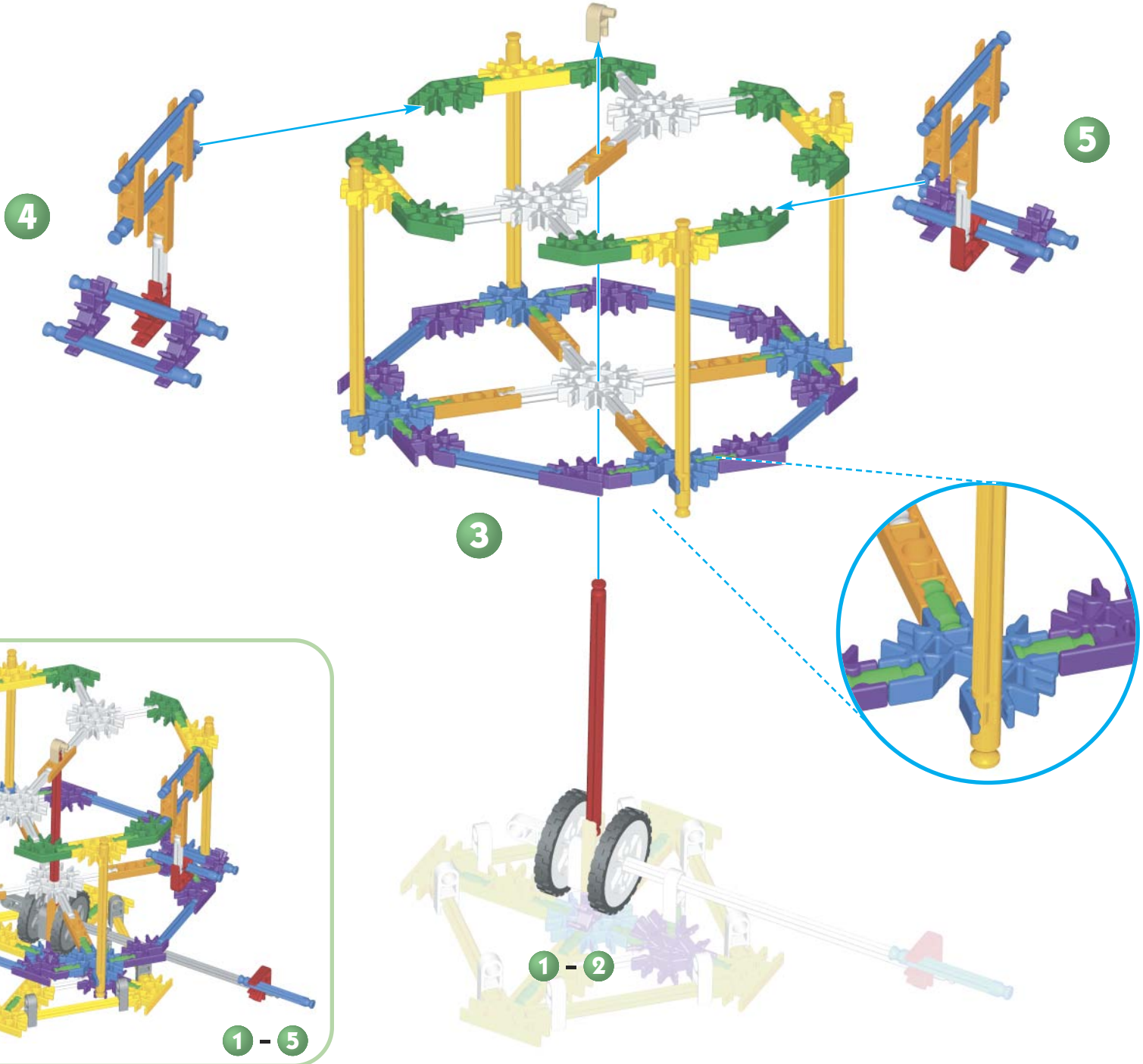

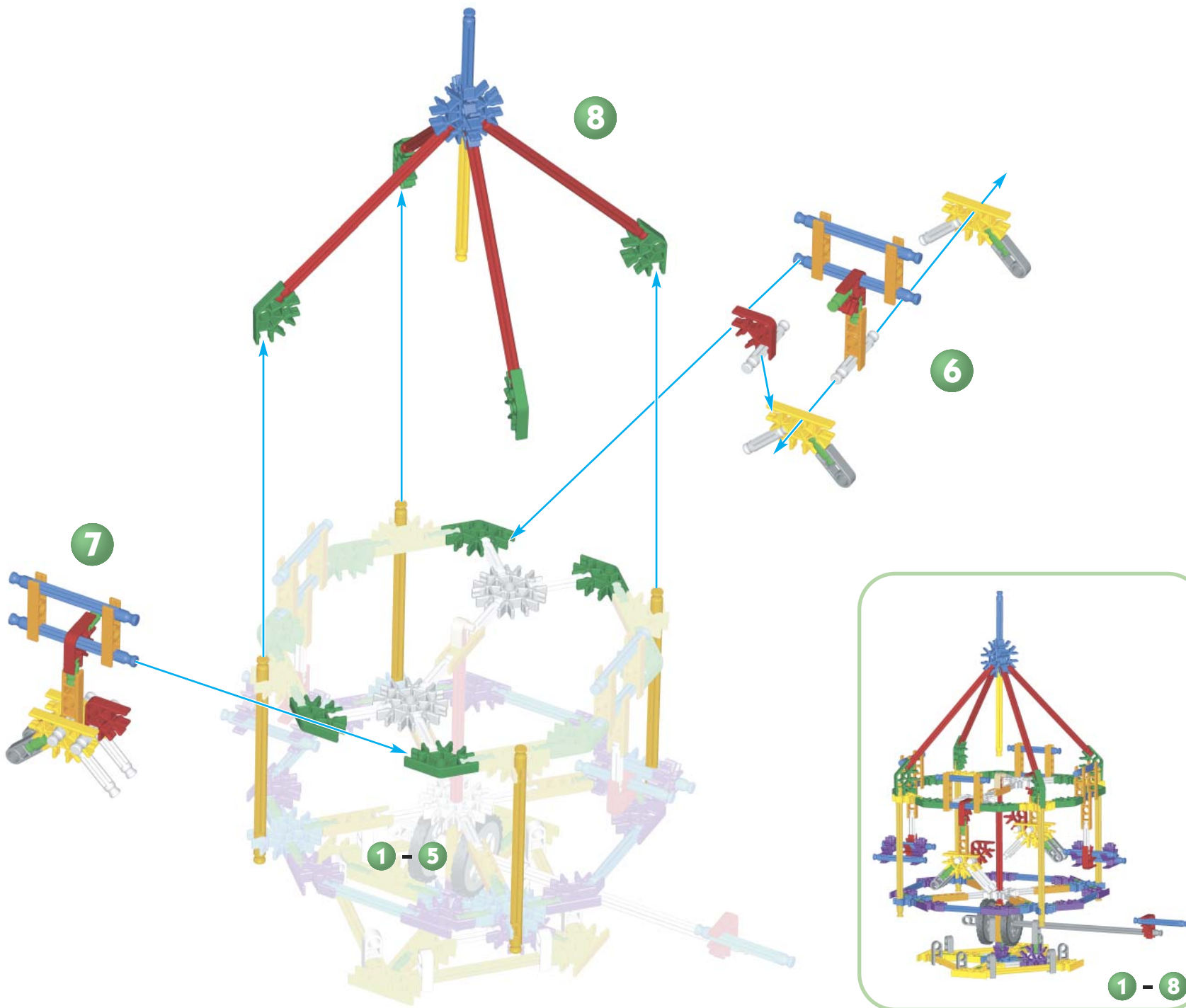

WHEELS & AXLES – Parts List
RUEDAS y EJES – Lista de Partes
ROULES et ESSIEUS – Liste de Pièces

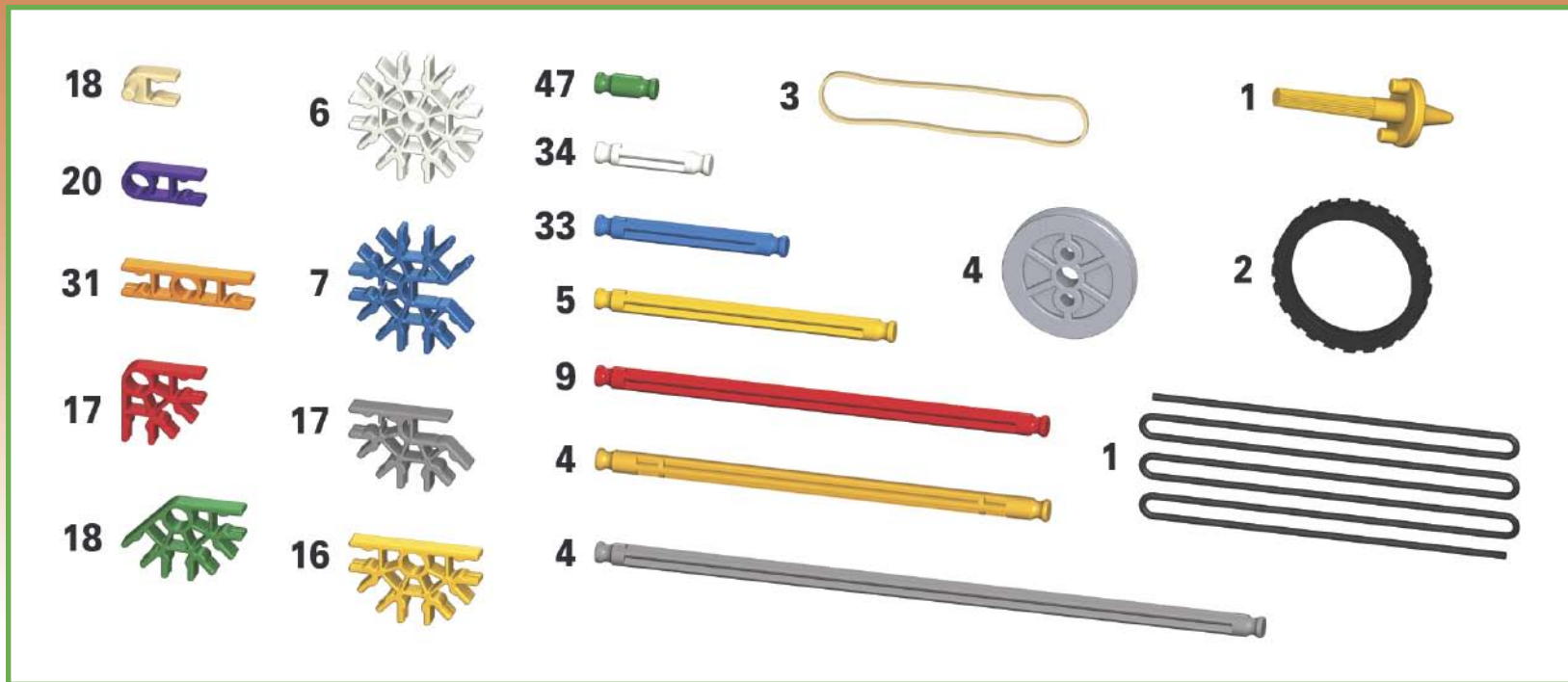

Product and colors may vary.
 K'NEX is a registered trademark of K'NEX Limited Partnership Group.

El producto y los colores podrán variar.
 K'NEX es una marca registrada de K'NEX Limited Partnership Group.

Le produit et les couleurs peuvent varier.
 K'NEX est une marques déposée de K'NEX Limited Partnership Group.

K'NEX Education
 P.O. Box 700
 Hatfield, PA
 19440-0700

1-888-ABC-KNEX
 (USA/Canada/EE.UU./États-Unis)

Email:
abcknex@knex.com

©2011 K'NEX Limited Partnership Group



17952003.11-V1-11/10