

## SIMPLE MACHINES DELUXE™

**INCLINED PLANES  
PLANOS INCLINADOS  
AVIONS INCLINÉS**

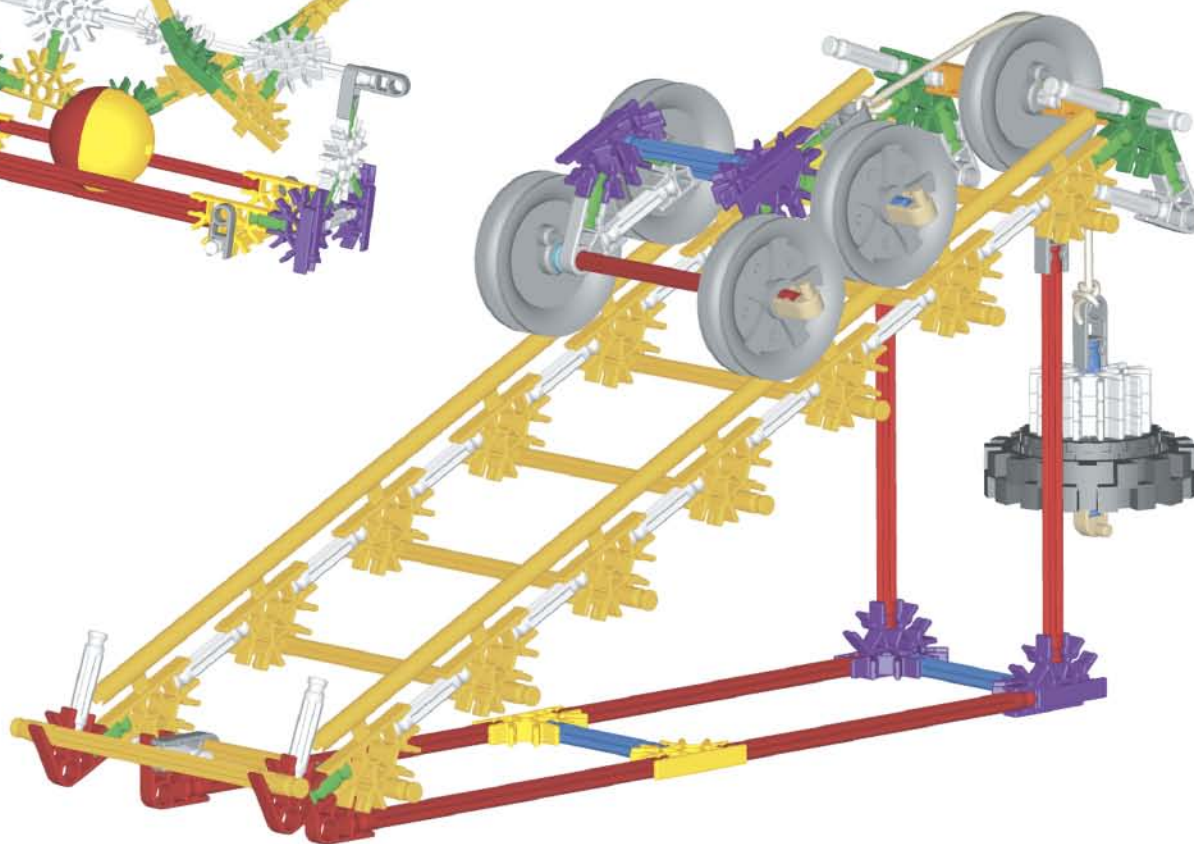
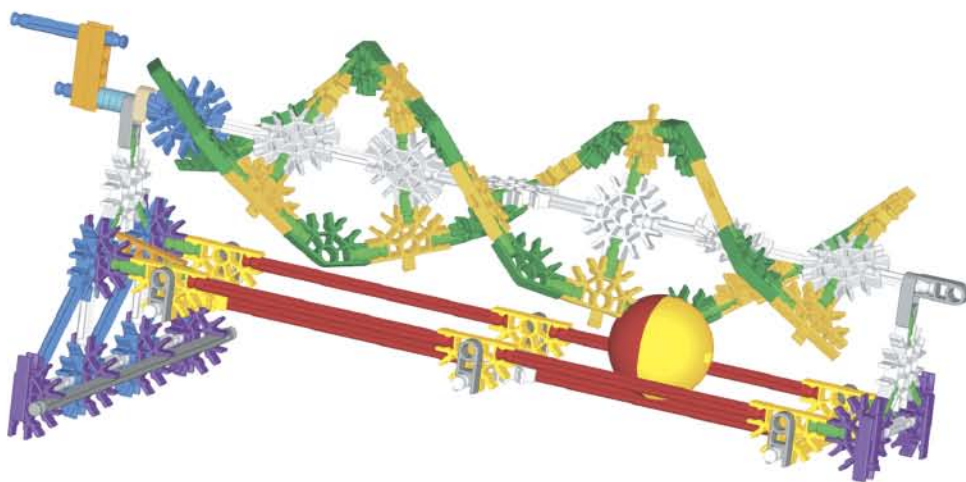

**⚠ WARNING:**

CHOKING HAZARD - Small parts.  
Not for children under 3 years.

**⚠ ADVERTENCIA:**

PELIGRO DE ASFIXIA - Piezas pequeñas.  
No es para niños menores de 3 años.

**⚠ AVERTISSEMENT :**

DANGER D'ÉTOUFFEMENT - Pièces de petite taille.  
Ne convient pas aux enfants de moins de 3 ans.

GRADES  
GRADOS  
ANNÉES  
**3-9**

**8+**

## EN CONTENTS

Roller Coaster Ramps	3
Moving Truck	6
Splitting Wedge	9
Chisel	10
Axe	11
Hand Drill	12
Archimedes Screw	13
Propeller	16
Playground Station	17

## ES CONTENIDOS

Rampas para la montaña rusa	3
Camión en movimiento	6
Cuña de separación	9
Cinzel	10
Hacha	11
Taladro de mano	12
Tornillo de Arquímedes	13
Hélice	16
Zona de juegos	17

## FR CONTENUS

Rampes de montagnes russes	3
Camion mobile	6
Coin fendeur	9
Burin	10
Hacha	11
Perceuse à main	12
Vis d'Archimède	13
Hélice	16
Terrain de jeu	17

**⚠ WARNING:** CHOKING HAZARD - Small parts. Not for children under 3 years.

**CAUTION:** Keep hair, clothing and fingers away from moving parts.

**⚠ ADVERTENCIA:** PELIGRO DE ASFIXIA - Piezas pequeñas. No es para niños menores de 3 años.

**PRECAUCIÓN:** Mantén el pelo, la ropa y los dedos alejados de las piezas móviles.

**⚠ AVERTISSEMENT :** DANGER D'ÉTOUFFEMENT - Petites pièces. Ne convient pas aux enfants de moins de 3 ans.

**ATTENTION :** Gardez les pièces mobiles à l'écart des doigts, des vêtements et des cheveux.

**⚠ CAUTION:** Rubber Bands can cause injury from snap-back, breaking, or loss of control. While assembling models shown in instructions, hold Rubber Band tightly, and do not overstretch. Use Rubber Bands only as shown in these instructions. **DO NOT USE FRAYED OR TORN RUBBER BANDS.** Caution: Keep Rubber Bands away from face and eyes.

**⚠ PRECAUCIÓN:** Las gomas pueden causar daños si se sueltan con fuerza, se rompen o se pierde su control. Al construir los modelos que se muestran en las instrucciones, sujetar bien la goma y no estirla demasiado. Las gomas deben usarse únicamente como se indica en las instrucciones. **NO USAR GOMAS QUE ESTÉN DESGASTADAS NI RASGADAS.** Precaución: Mantenga las gomas elásticas alejadas de la cara y los ojos.

**⚠ ATTENTION :** Les élastiques peuvent causer des blessures en claquant, en se cassant ou quand on les manipule imprudemment. Tenez fermement l'élastique lors de l'assemblage du modèle en veillant à ne pas trop le tendre. N'utilisez les élastiques que selon les instructions. **N'UTILISEZ PAS D'ÉLASTIQUES ÉRAILLÉS OU DÉCHIRÉS.** Attention : Tenez les élastiques en caoutchouc à l'écart du visage et des yeux.

There are places in your model where you need to add blue spacers. Be sure to count them carefully.

Dans ton modèle, il y a des endroits où il faudra ajouter des entretoises bleues. Soyez sûrs de les compter soigneusement.

Hay lugares en tu modelo donde tendrás que agregar espaciadores azules. Esté seguro para contarlos con cuidado.

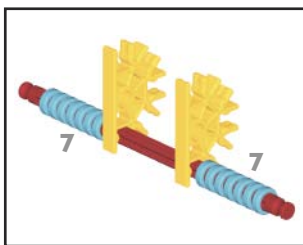

Each K'NEX piece has its own color and shape; match it to pieces in the picture instructions. Put pieces together exactly as pictures show. Be sure to put rods in the correct slots of connectors, so you have proper angles in your finished model.

Assurez-vous de bien assembler les tiges dans les fentes des connecteurs afin d'obtenir des angles corrects une fois le modèle fini. Asegurarse de colocar las varillas en las ranuras correctas de los conectores, de modo que al terminar el modelo, los ángulos sean los adecuados.

Chaque pièce K'NEX a une couleur et une forme bien à elle. Faites correspondre et montez les pièces les unes sur les autres en suivant exactement les instructions illustrées. Assurez-vous de bien assembler les tiges dans les fentes des connecteurs afin d'obtenir des angles corrects une fois le modèle fini.

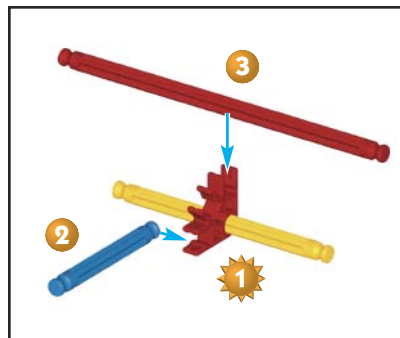

Faded colors indicate sections previously built; connecting points will be in full color.

Los colores apagados indican secciones que ya han sido montadas anteriormente. Los puntos de conexión se indican con colores vivos.

Les couleurs plus claires indiquent les sections déjà construites. Les points de jonction sont indiqués en couleurs vives.

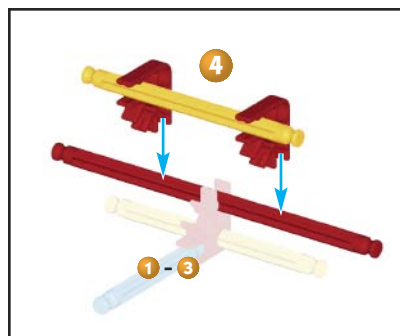

You can slide these special connectors together. Push tightly until you hear a "click". Pay close attention to the instructions and position them horizontally or vertically exactly as they are shown.

Se puede juntar estos conectores especiales deslizándolos. Empujar ligeramente hasta oír un "clic". Hace falta prestar mucha atención a las instrucciones y posicionar los conectores horizontal o verticalmente exactamente tal como se muestran.

Les connecteurs bleus et gris ont une longue encoche spécialement conçue pour s'emboîter les unes dans les autres, tel qu'illustré. Bien les pousser ensemble jusqu'à ce qu'un dé clic se fasse entendre.

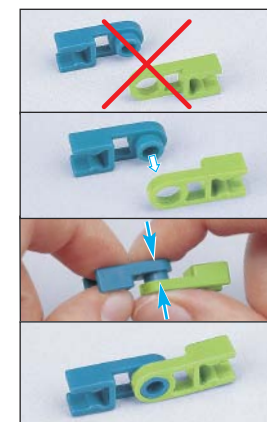
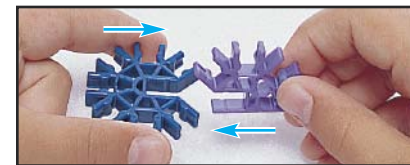
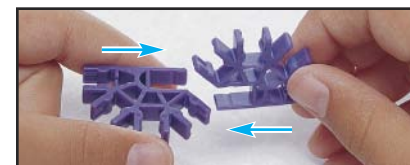
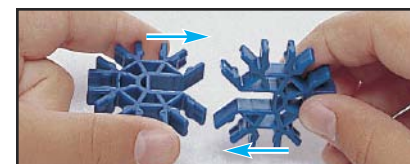

# Roller Coaster Ramps

## Rampas para la montaña rusa

### Rampes de montagnes russes

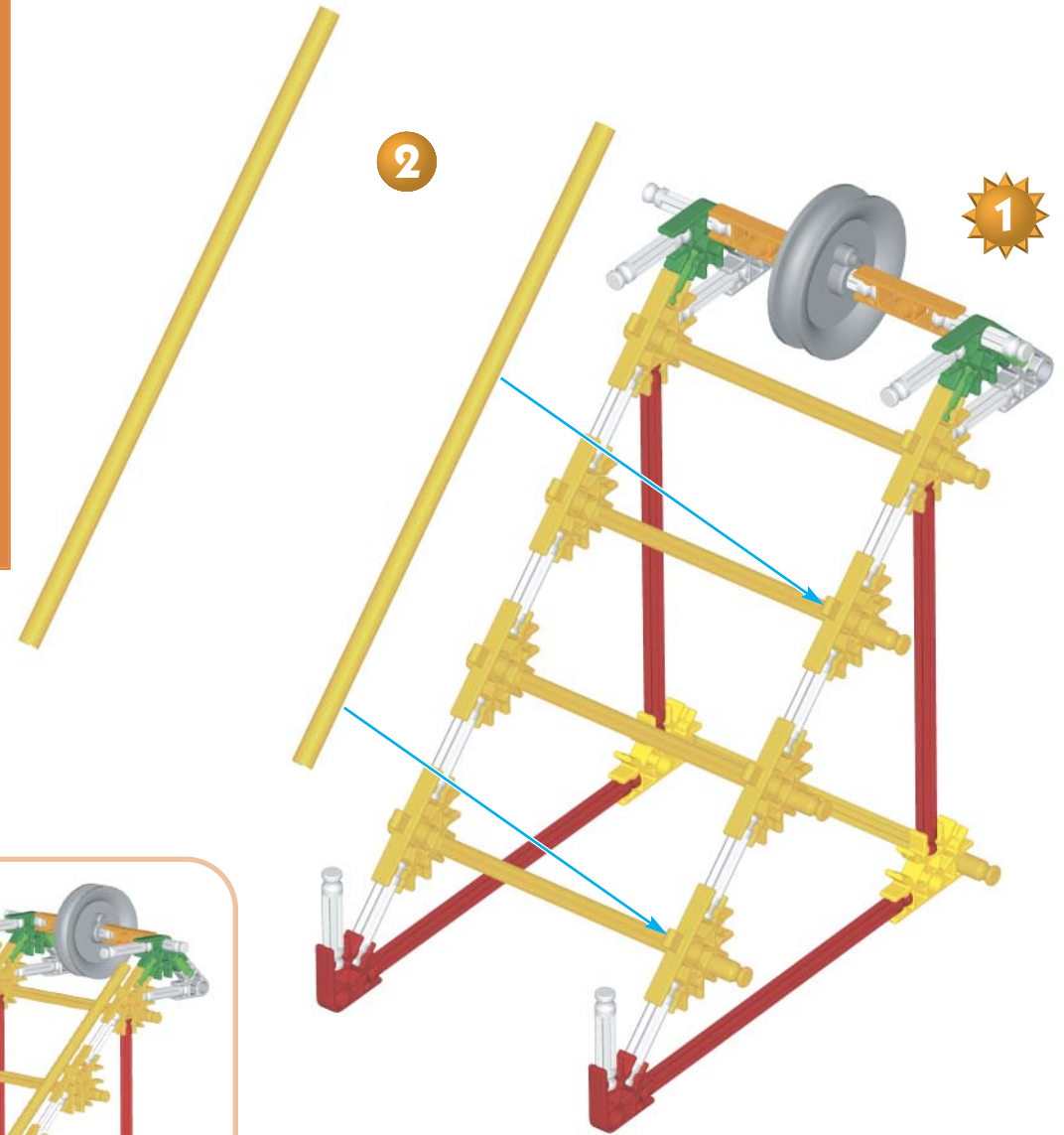
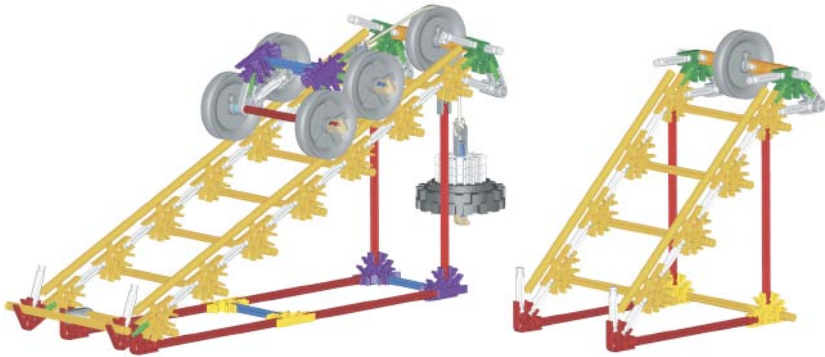

**K'NEX** Education

5		4		8		1	
6		5		15		1	
4		22		42		1	
8		8		6		7	
6		3		11		1	
		13				1	
						1	



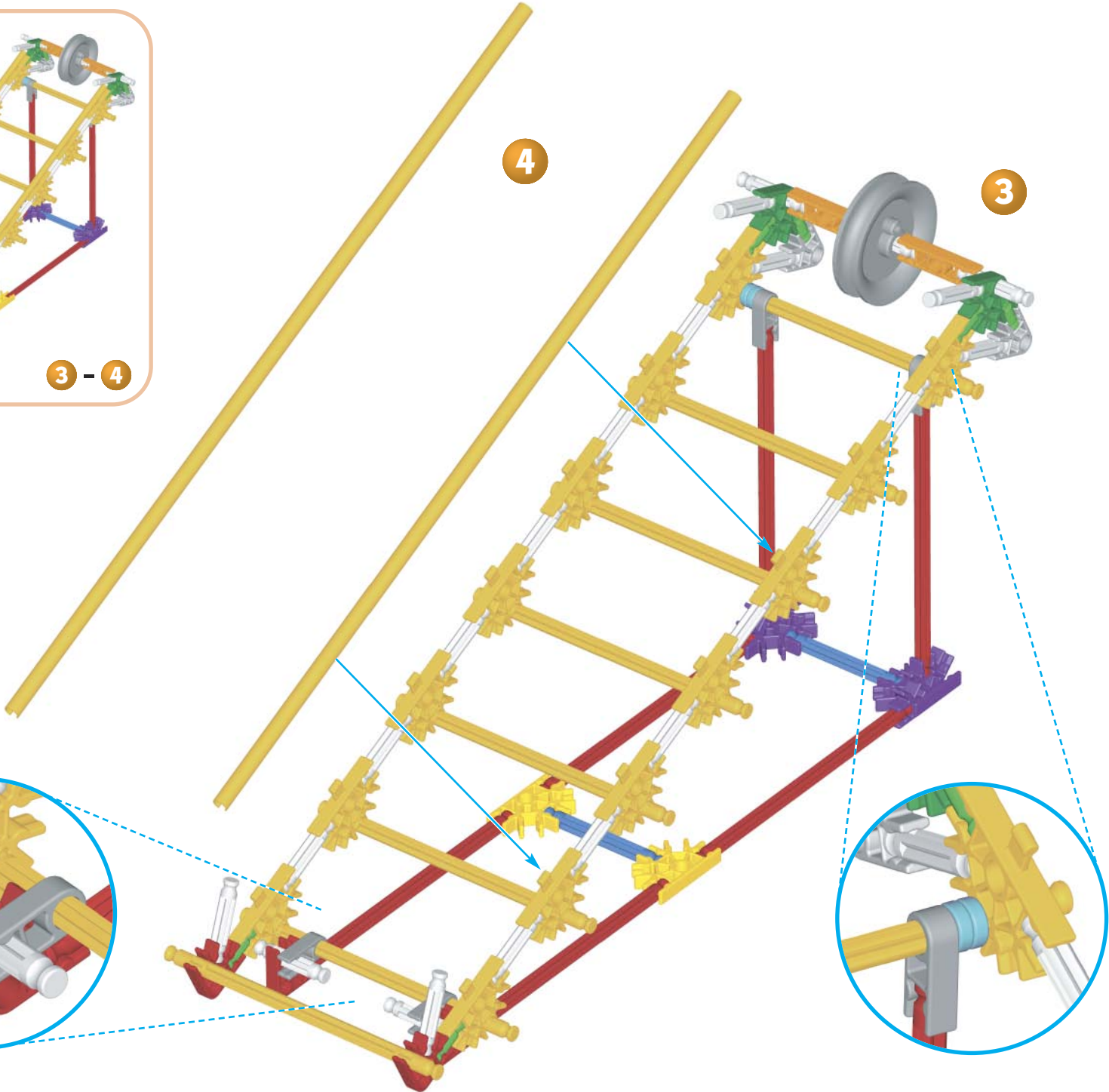

Tie the ends of cord through these gray Connectors  
Ate los extremos del cable a través de estos conectores grises.  
Attacher les bouts de la corde dans ces connecteurs gris.

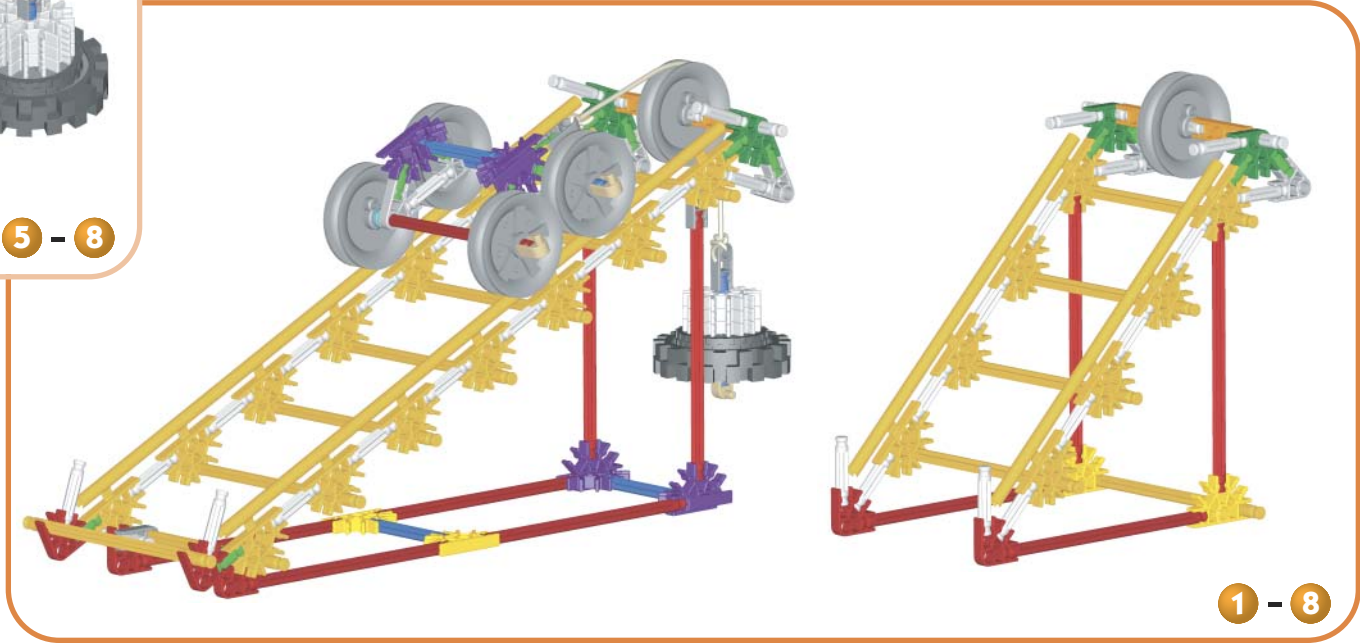
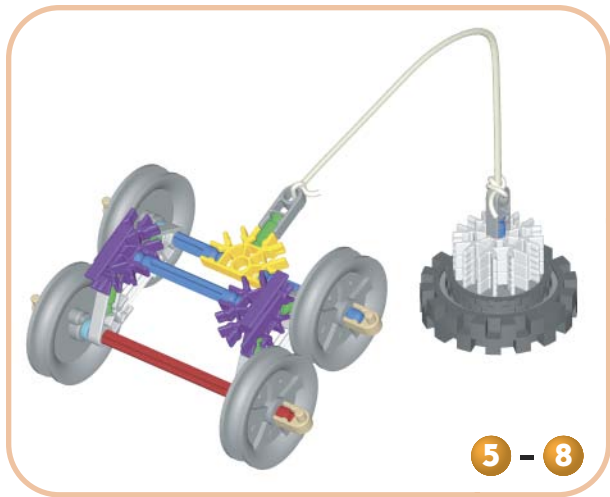
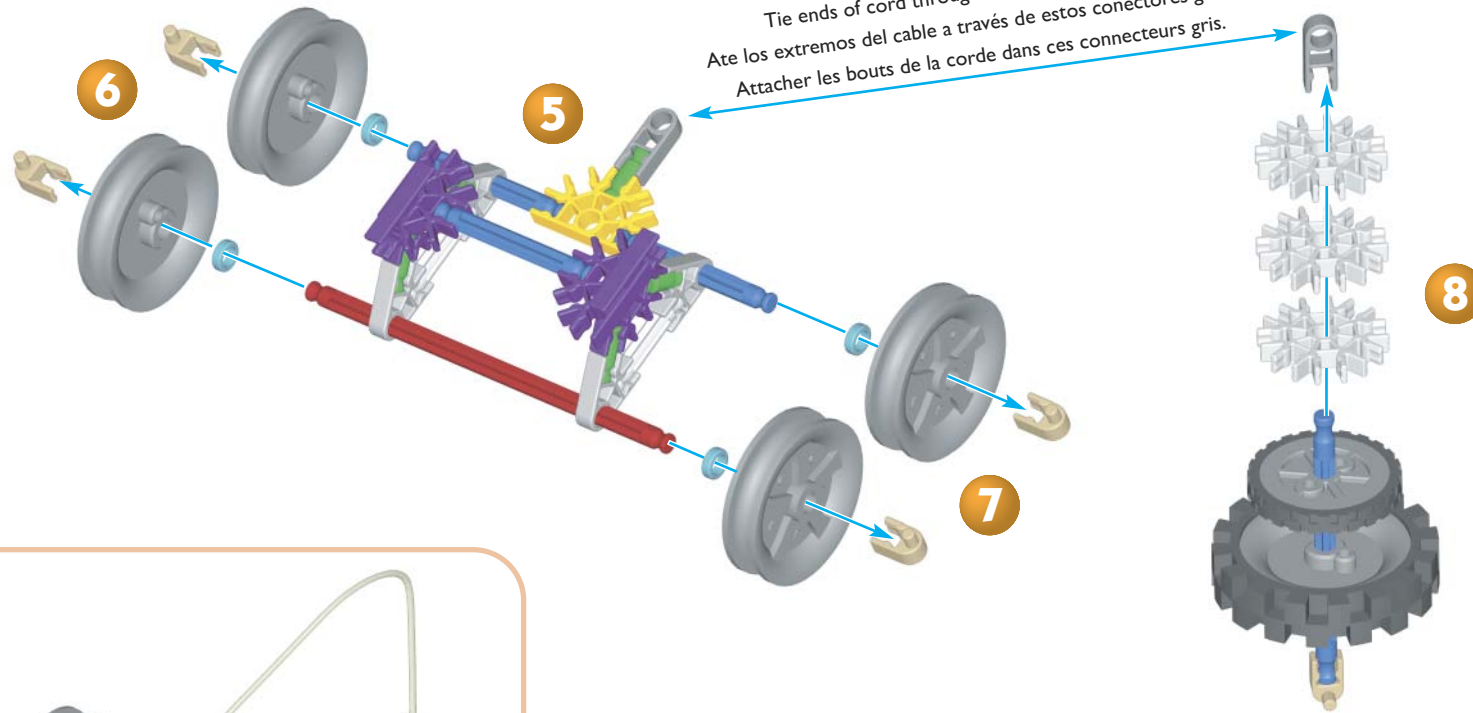

# Moving Truck

Camión en movimiento

Camion mobile

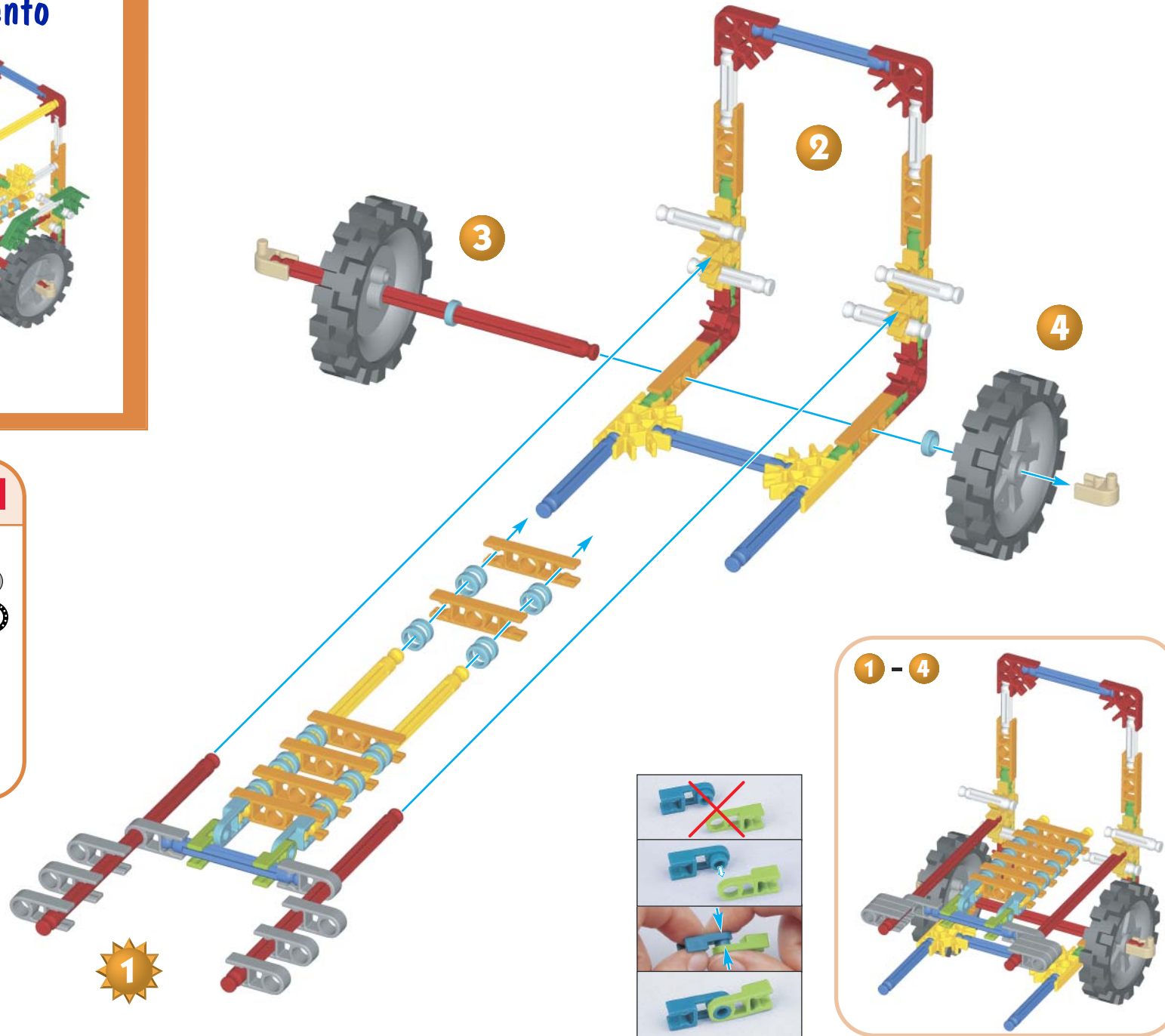

**K'NEX** Education

- |    |   |    |   |   |   |
|----|---|----|---|---|---|
| 4  | ⇒ | 24 | ○ | 2 | ⊙ |
| 8  | ⊢ | 43 | — | 4 | ⊙ |
| 12 | ⊢ | 28 | — | 4 | ⊙ |
| 12 | ⊢ | 12 | — |   |   |
| 8  | ⊢ | 4  | — |   |   |
| 8  | ⊢ | 4  | — |   |   |
| 6  | ⊢ | 2  | ⊢ |   |   |
| 10 | ⊢ | 2  | ⊢ |   |   |
| 6  | ⊢ |    |   |   |   |

**⊢ = ⊢**

**⊢ = ⊢**

**⊢ = ⊢**

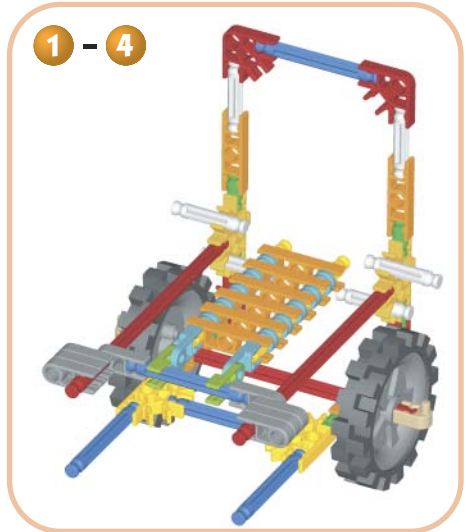
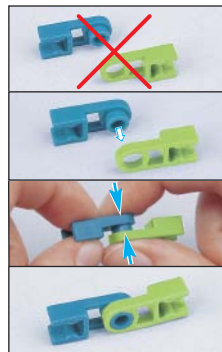

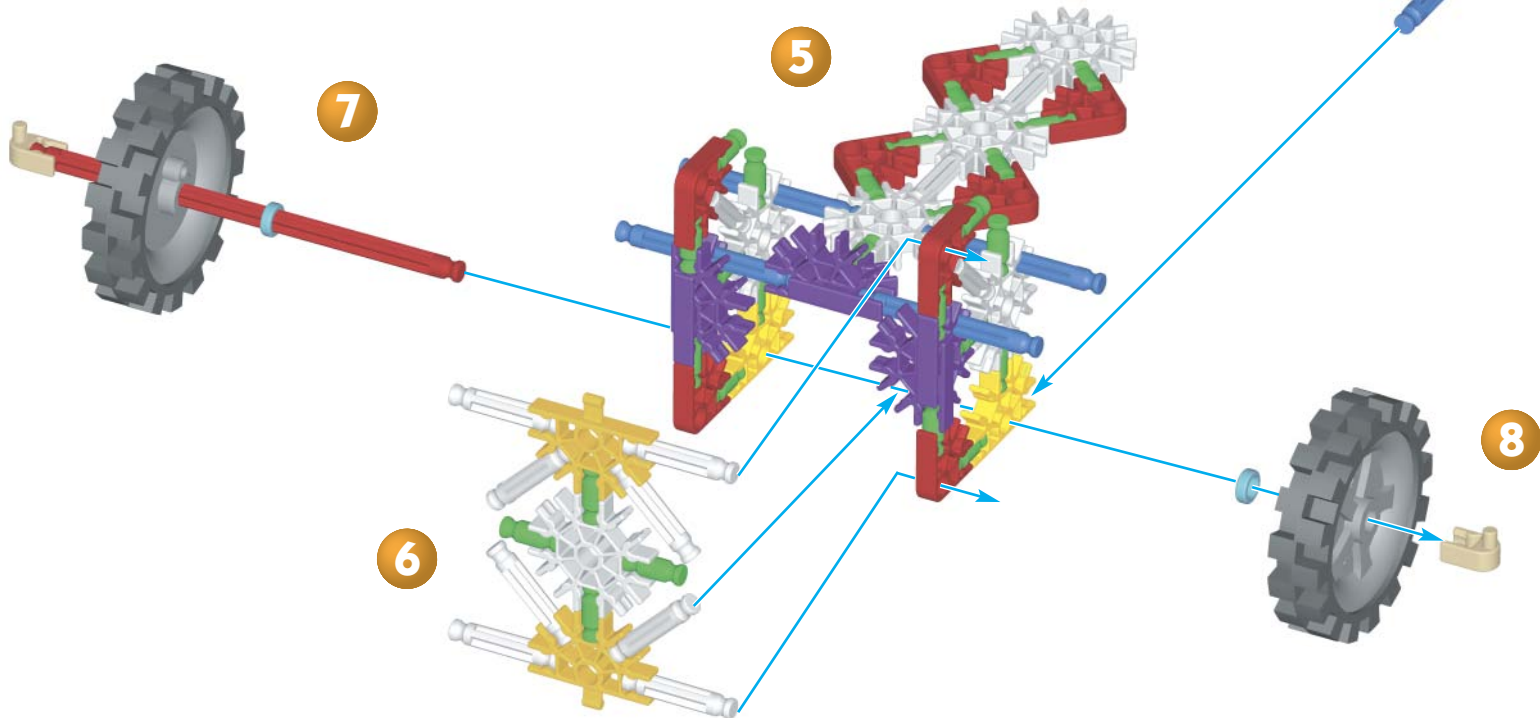
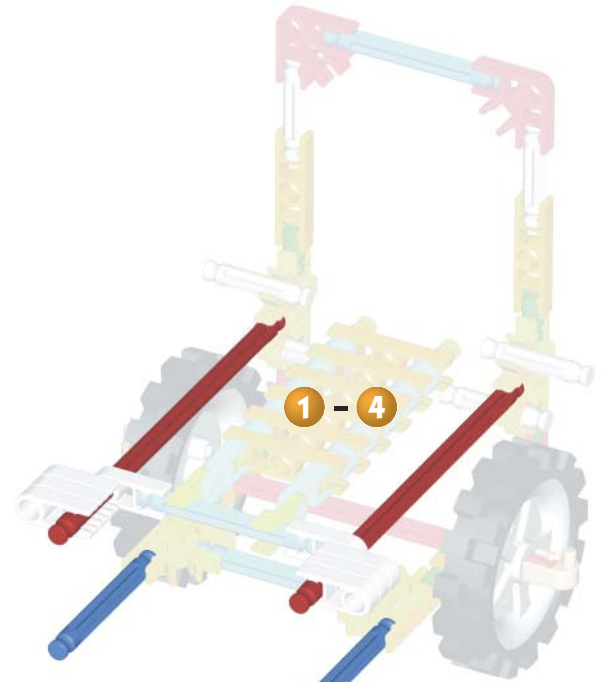
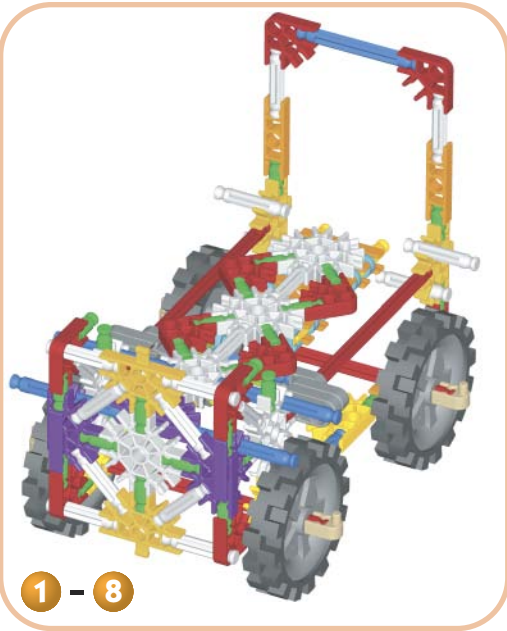

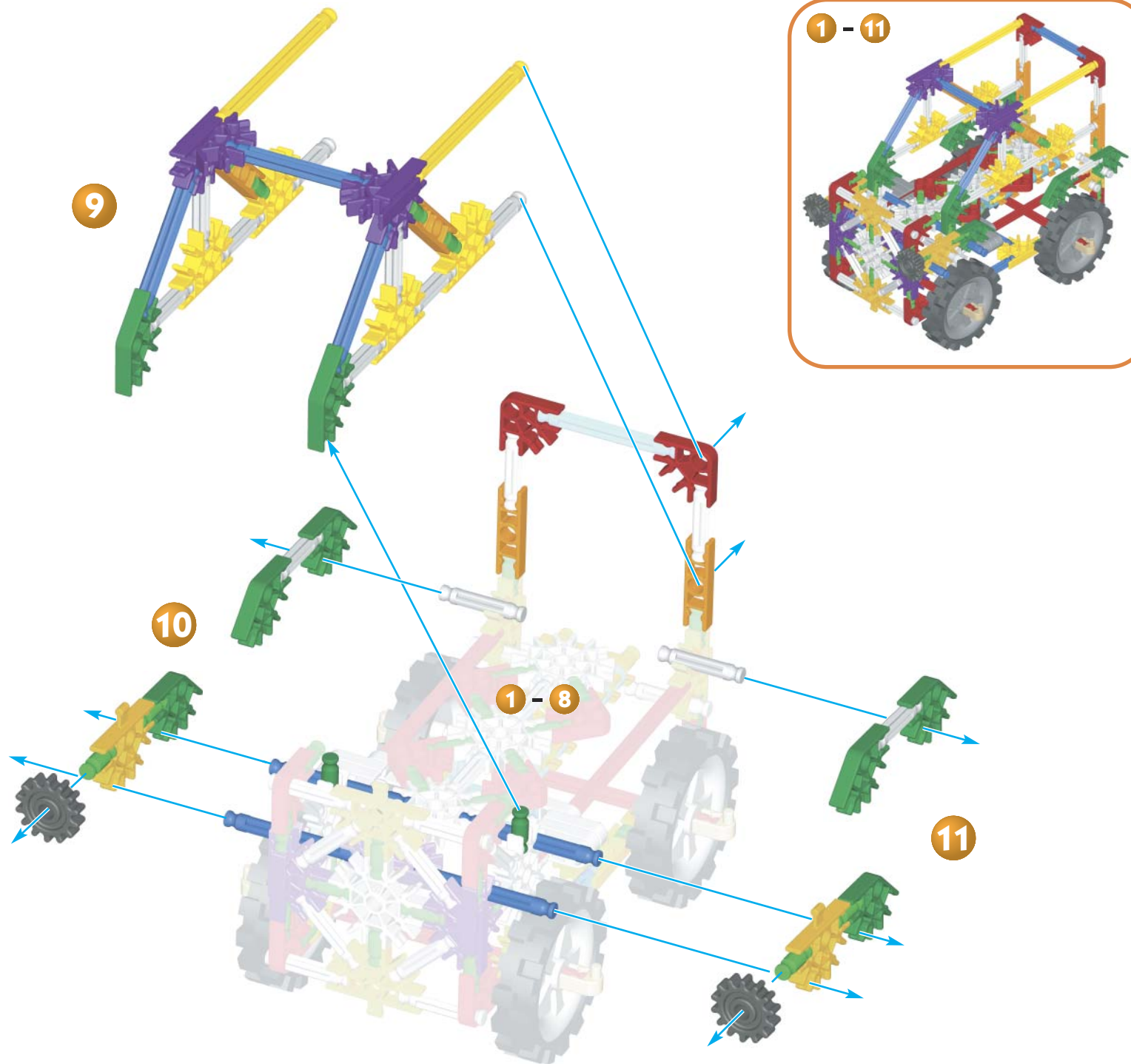



# Splitting Wedge

## Cuña de separación

### Coin fendeur



1

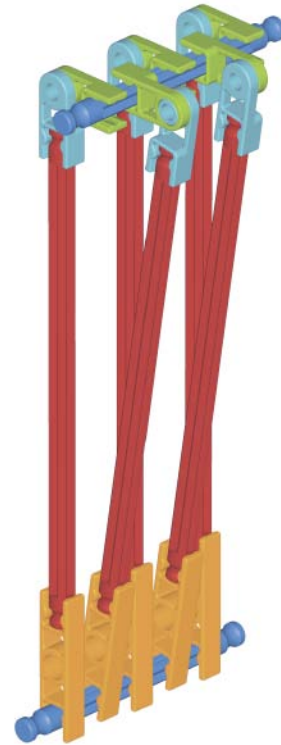

2

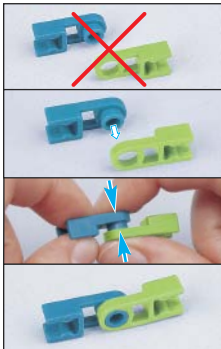
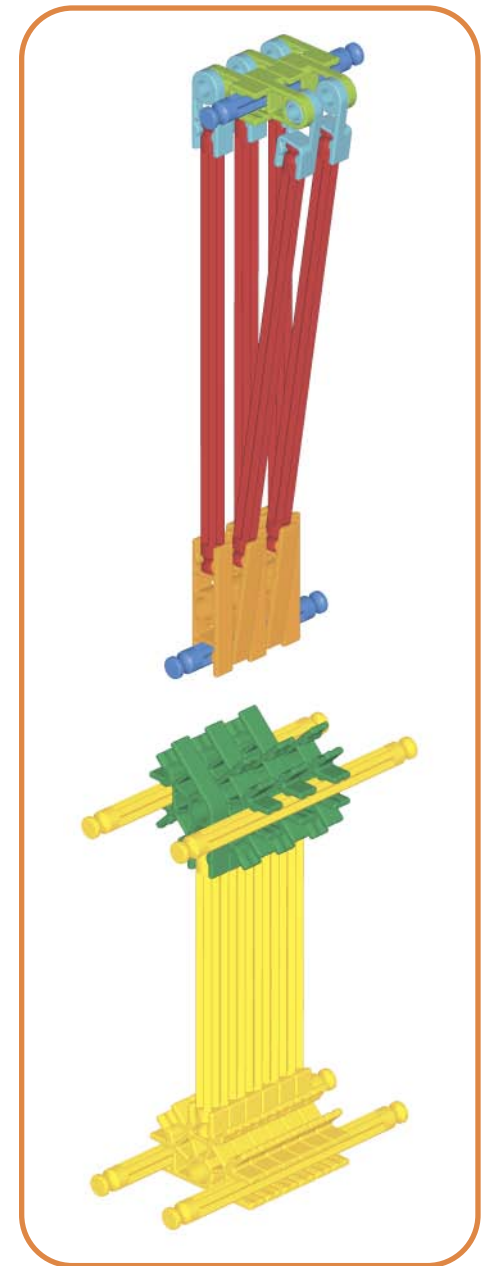
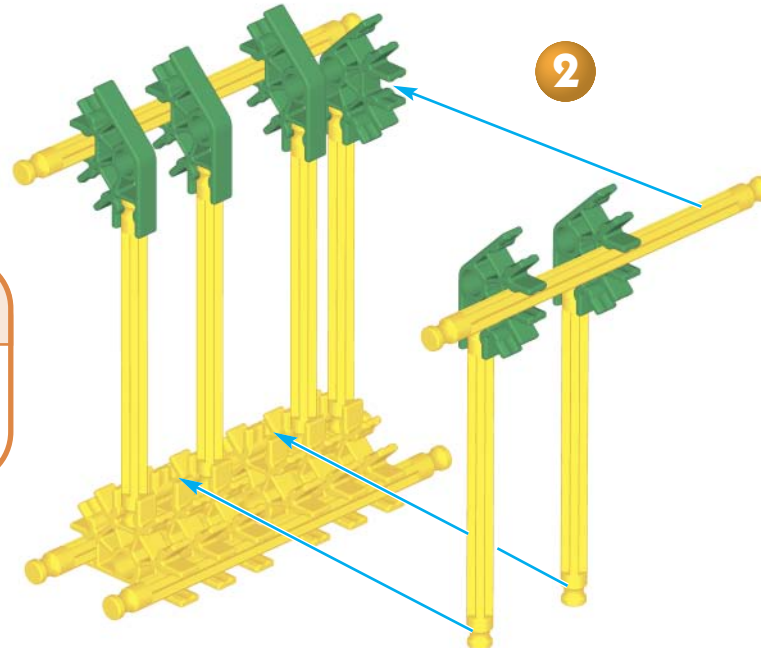

**K'NEX** Education

- |   |  |    |  |   |  |
|---|--|----|--|---|--|
| 5 |  | 2  |  | 5 |  |
| 6 |  | 10 |  | 5 |  |
| 6 |  | 5  |  |   |  |



**Chisel  
Cinzel  
Burin**

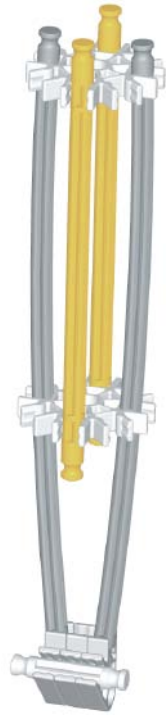

**K'NEX** Education

- |   |   |   |   |
|---|---|---|---|
| 3 |  | 1 |  |
| 2 |  | 2 |  |
|   |   | 2 |  |

Axe  
Hache  
Hacha

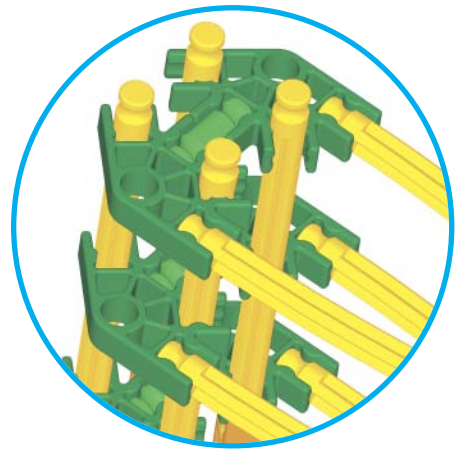
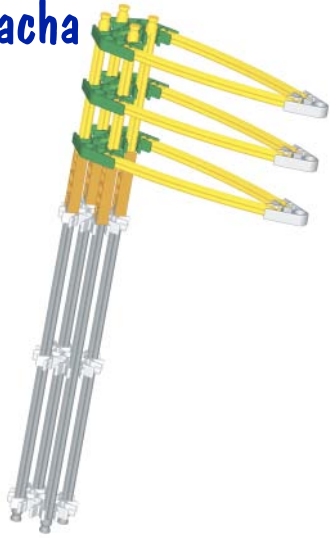

1



2

3

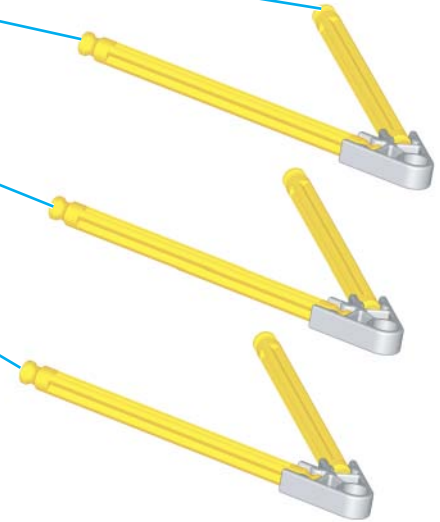

K'Nex Education

4		3	
3		10	
6		4	
3			

# Hand Drill

## Taladro de mano

### Perceuse à main

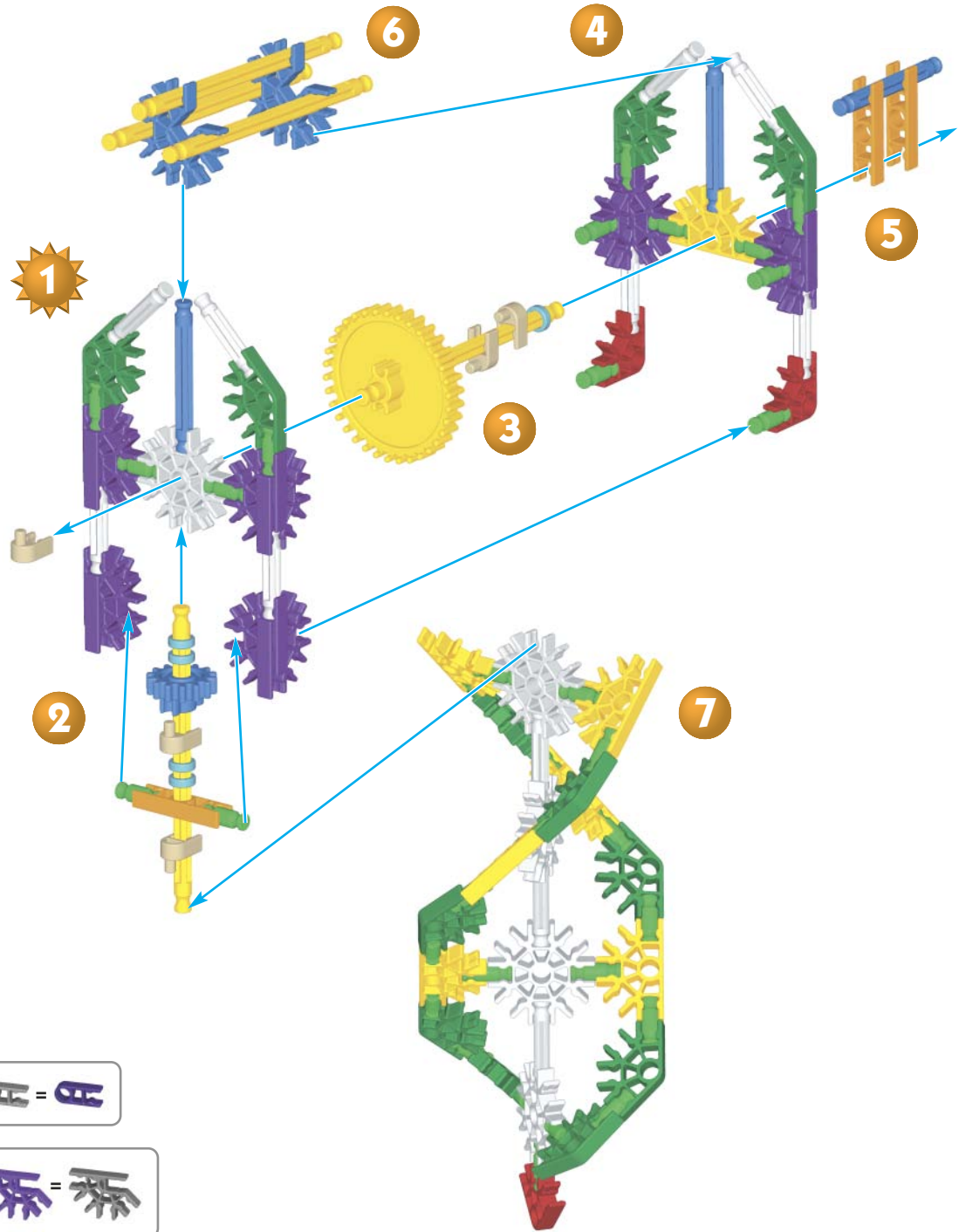

**K'NEX Education**

5		5		1	
3		35		1	
3		11			
12		3			
7		5			
12					
2					
5					



# Archimedes Screw

## Tornillo de Arquímedes

### Vis d'Archimède

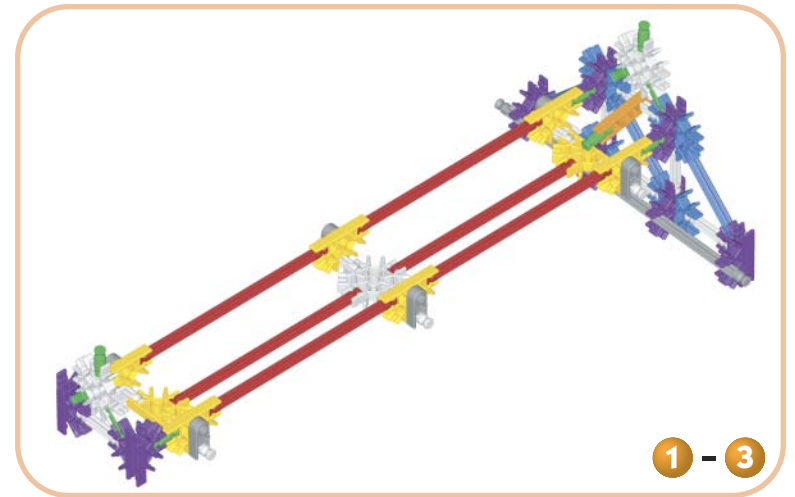
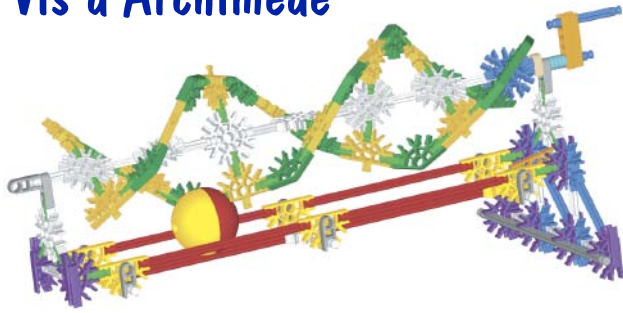

**K'NEX** Education

1	4	1
9	49	1
3	20	
14	5	
8	6	
12	1	
12		
6		
9		

 = 

 = 

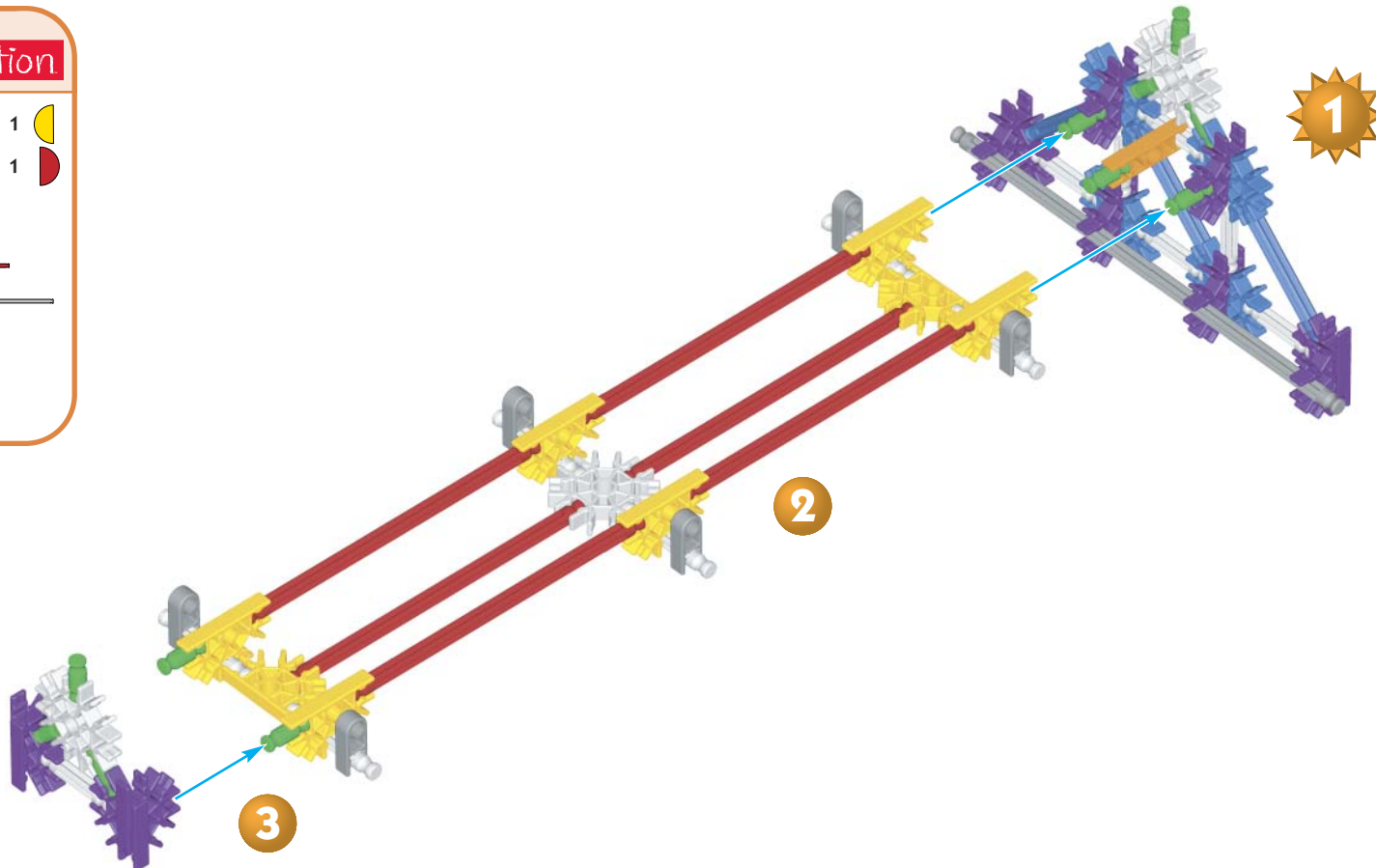

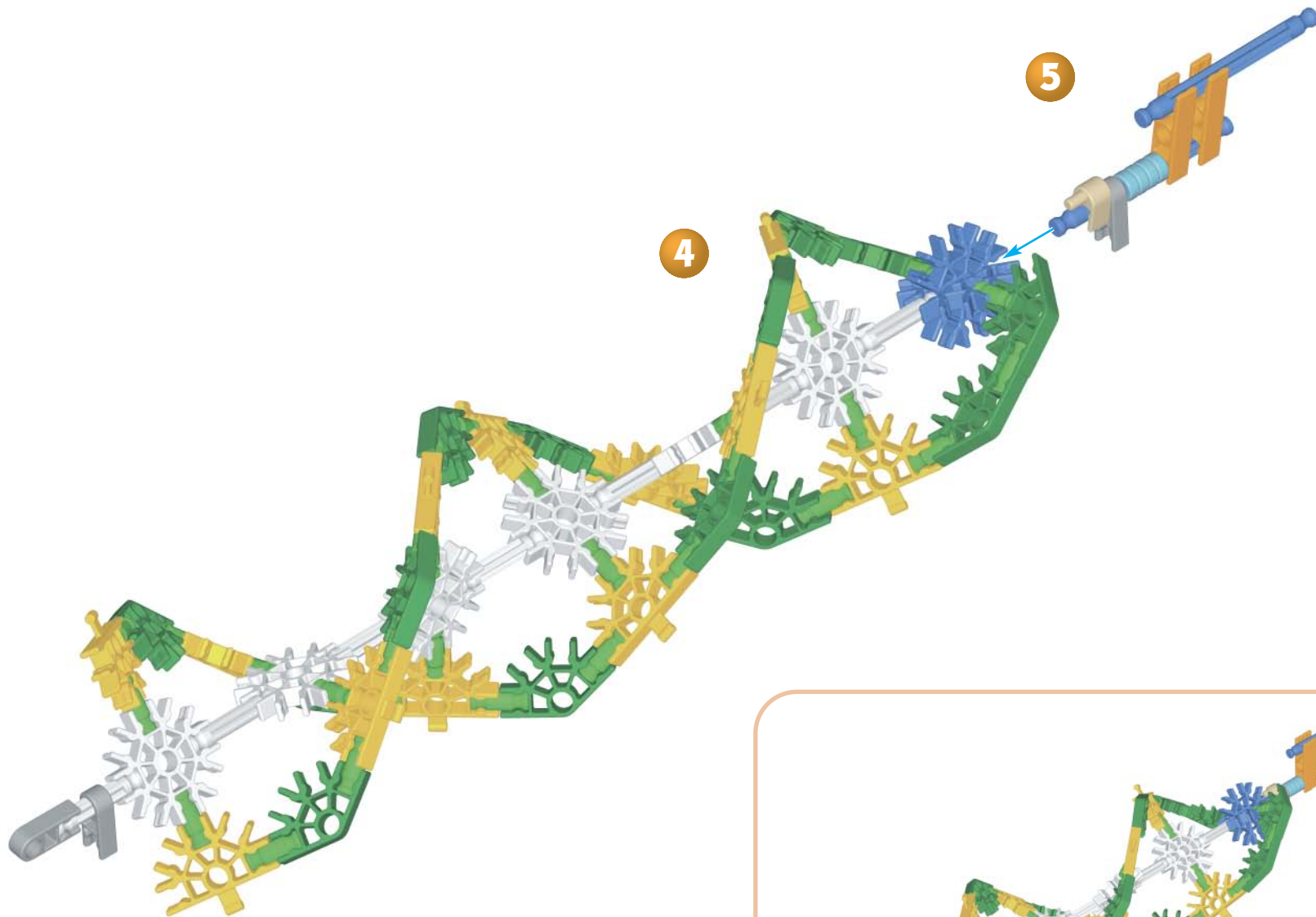

4 - 5

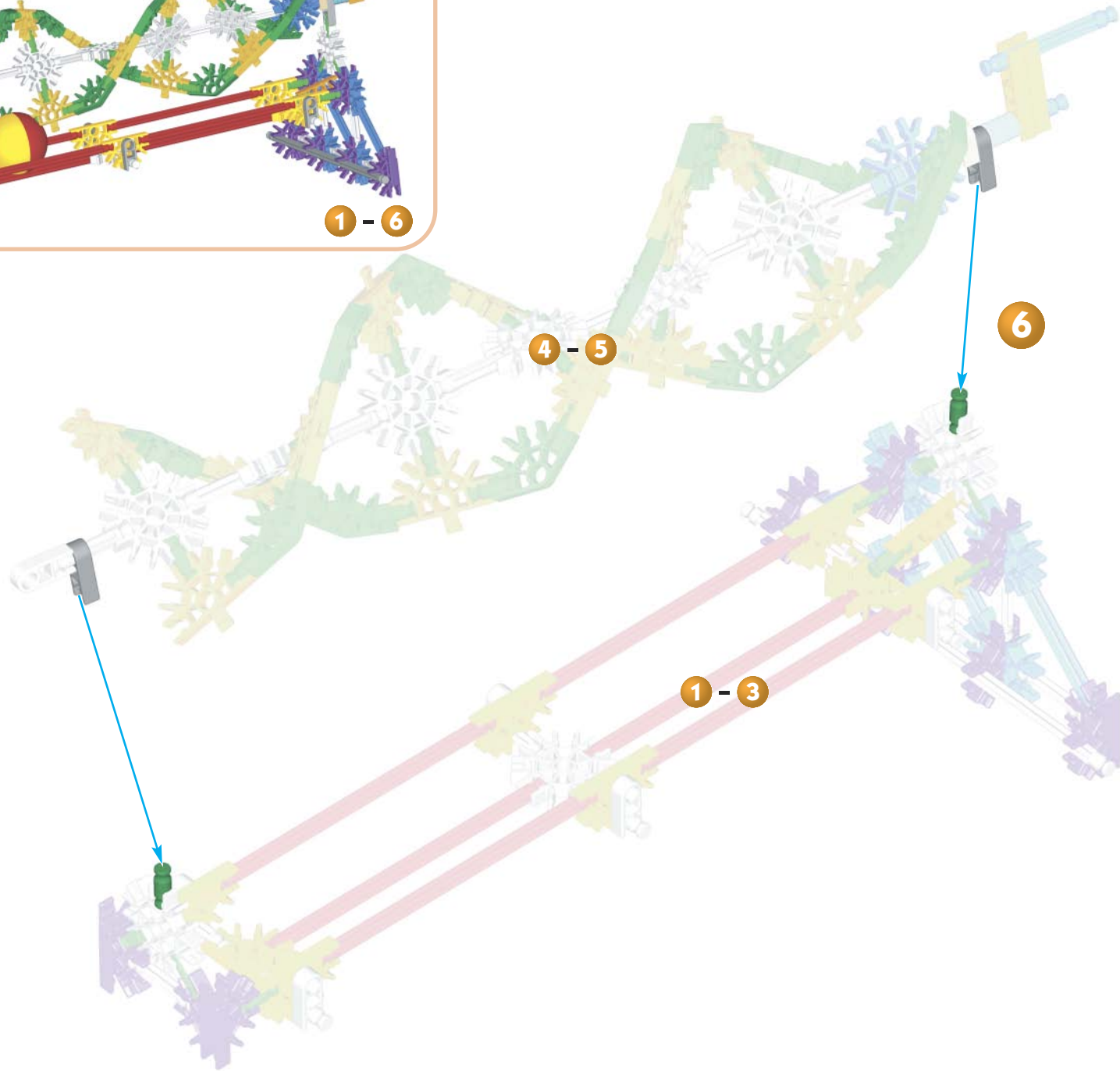
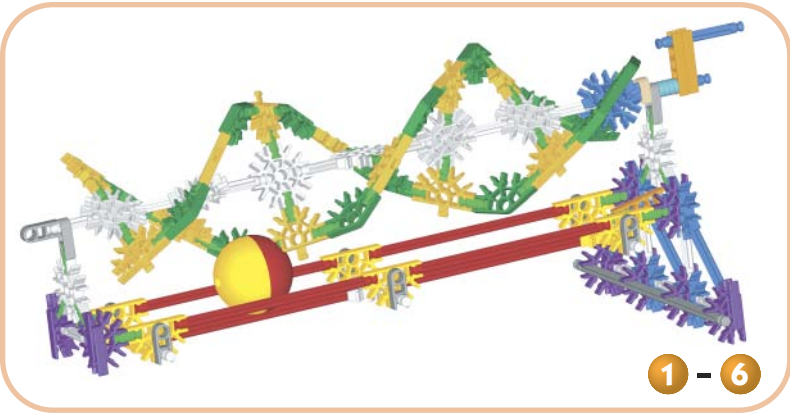

Propeller  
Hélice  
Hélice

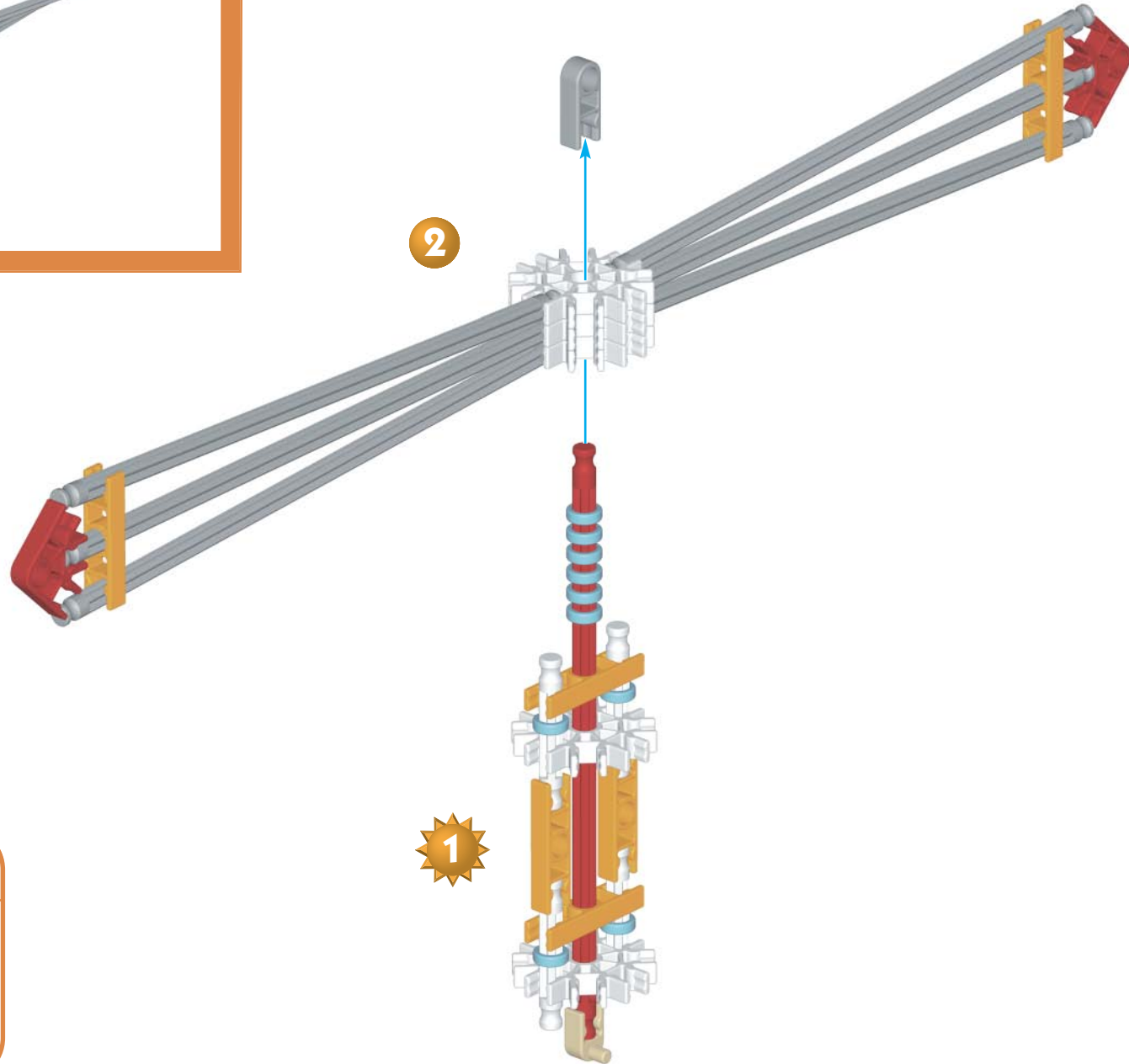
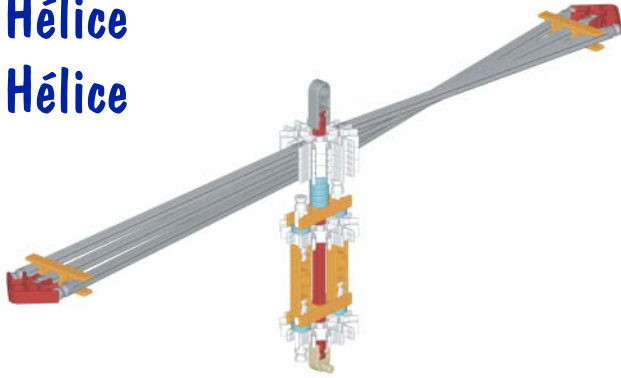

**K'NEX Education**

1	⇒	10	●
1	⇒	4	—
6	⇒	1	—
2	⇒	6	—
5	⇒		☼



# Playground Station Terrain de jeu Zona de juegos

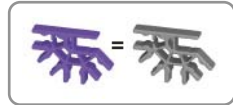
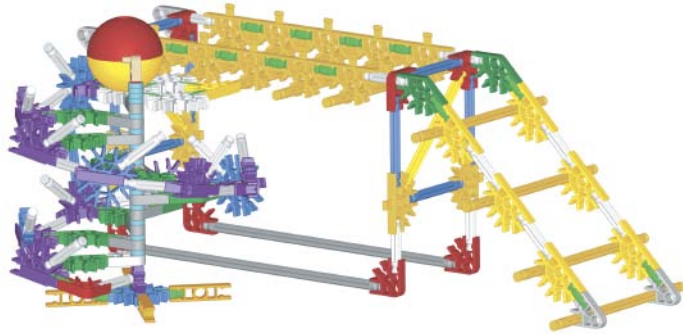

**K'NEX Education**

1		8		45		14	
10		14		34		1	
4		19		9		1	
5		5		2			
9		3		1			
12				9			
				2			

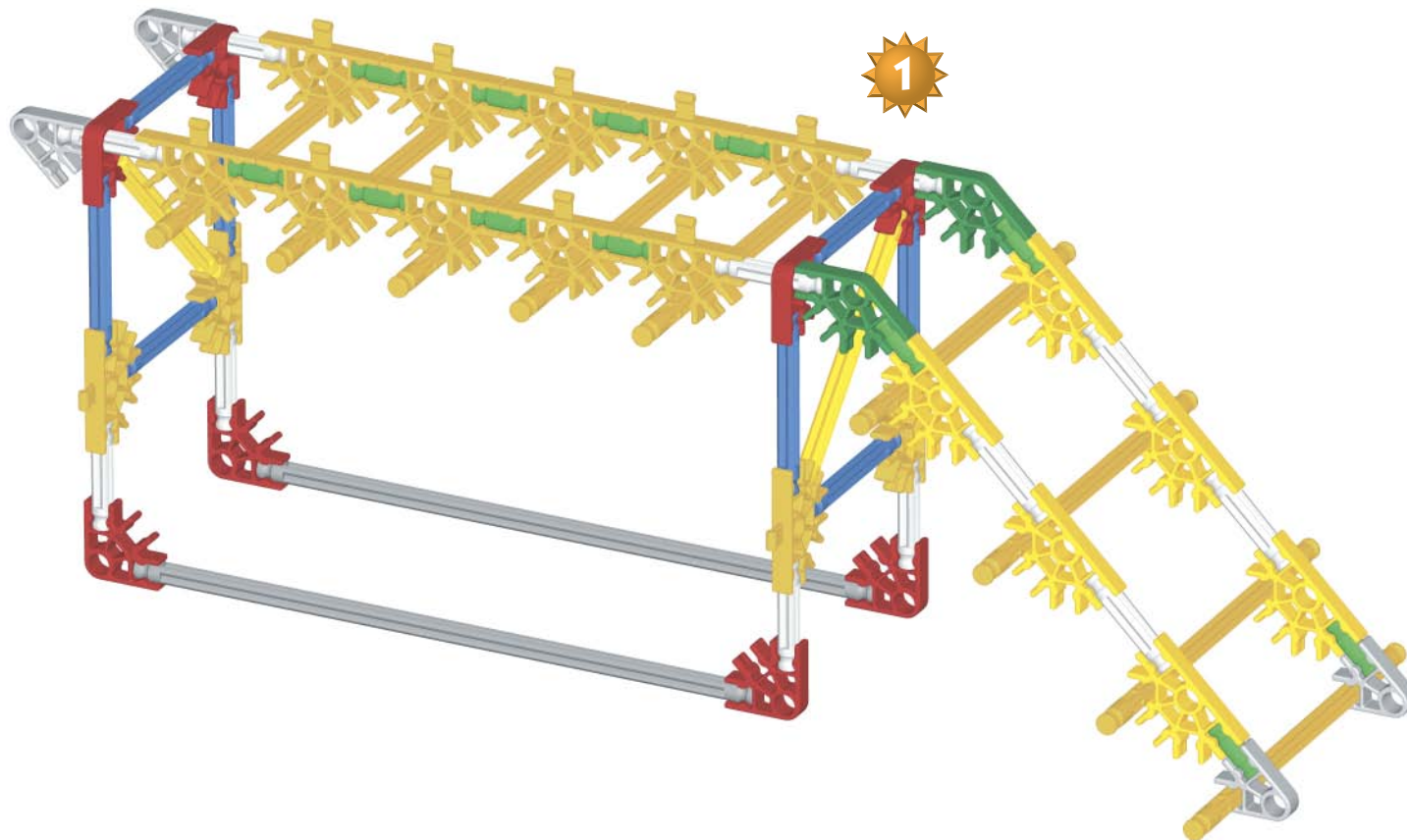

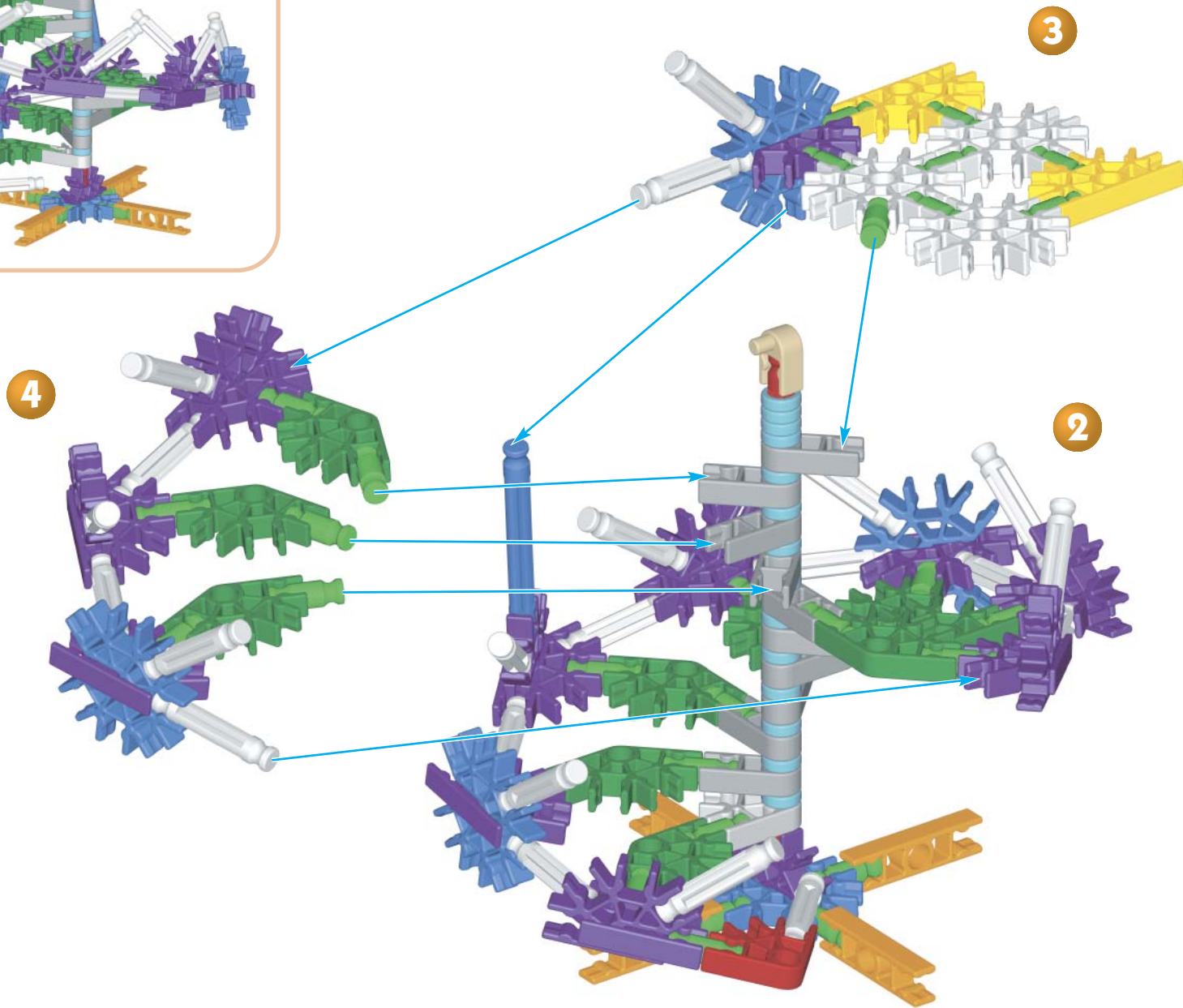
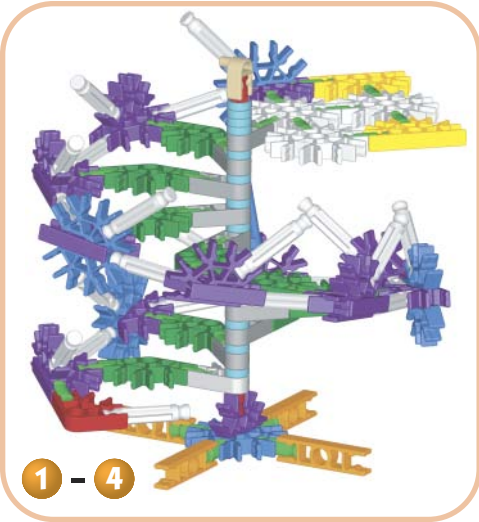

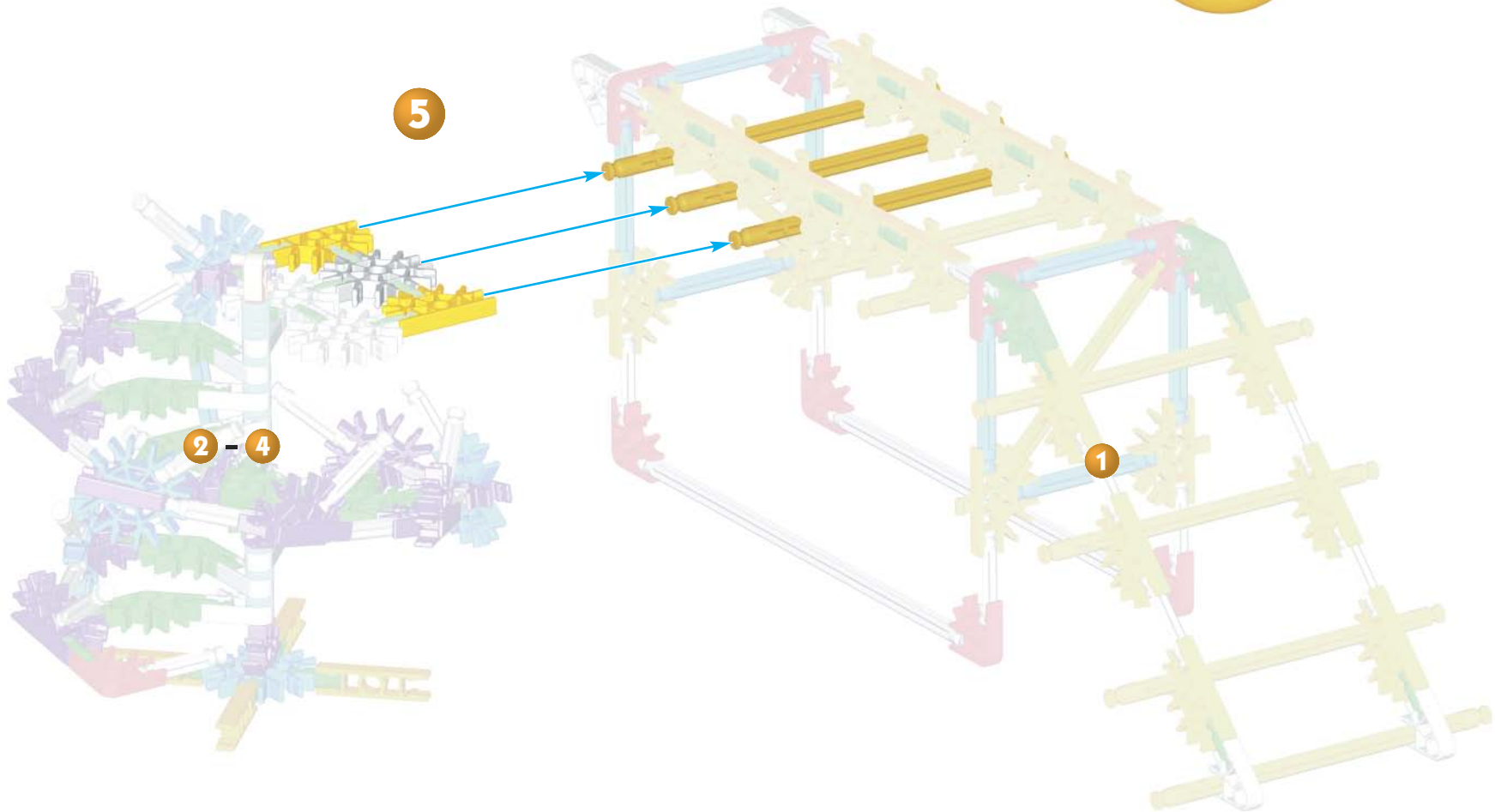
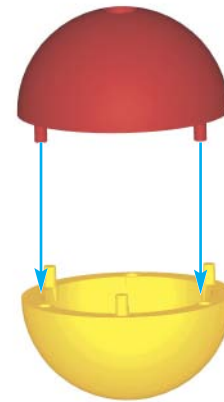
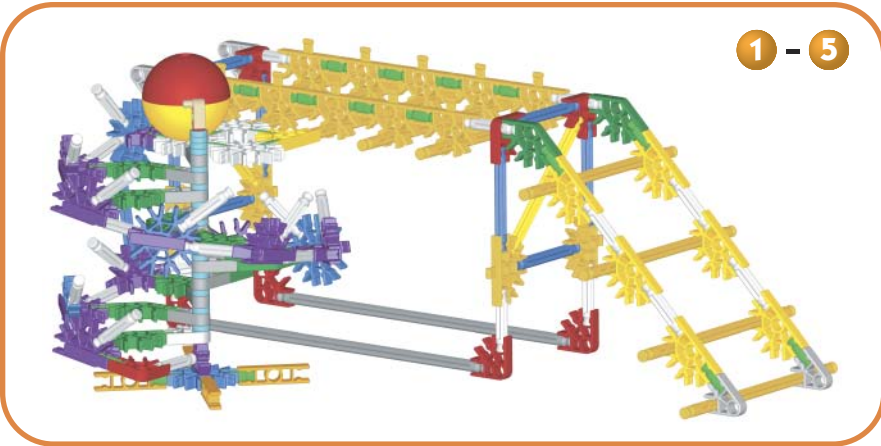

**INCLINED PLANES – Parts List**  
**PALNOS INCLINADOS – Lista de Partes**  
**AVIONS INCLINÉS – Liste de Pièces**

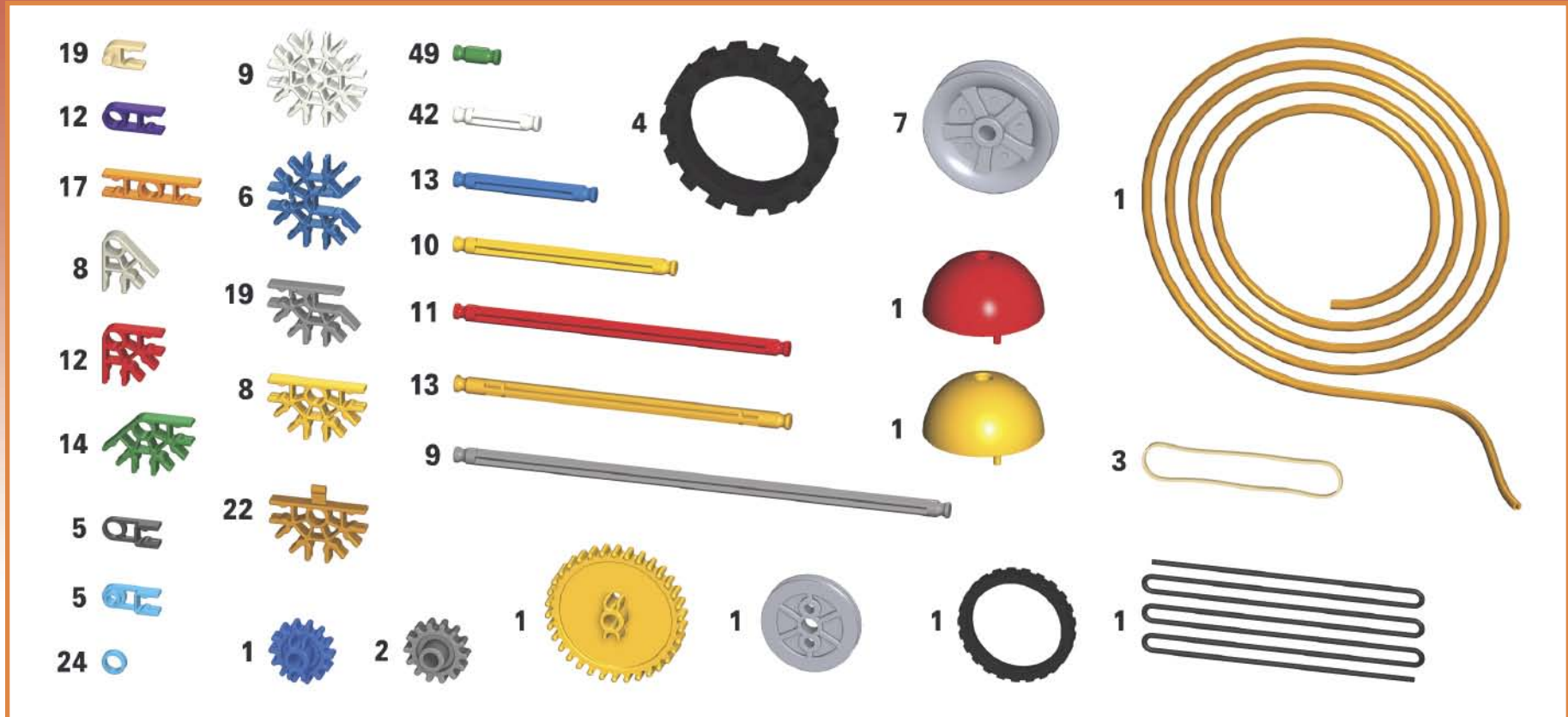

Product and colors may vary.  
 K'NEX is a registered trademark of K'NEX Limited Partnership Group.

El producto y los colores podrán variar.  
 K'NEX es una marca registrada de K'NEX Limited Partnership Group.

Le produit et les couleurs peuvent varier.  
 K'NEX est une marques déposée de K'NEX Limited Partnership Group.

K'NEX Education  
 P.O. Box 700  
 Hatfield, PA  
 19440-0700

1-888-ABC-KNEX  
 (USA/Canada/EE.UU./États-Unis)

Email:  
 abcknex@knex.com

©2011 K'NEX Limited Partnership Group



17952005.11-V1-11/10